

# OTTOBRE

design®

6/2015 Winter

## INSTRUCTIONS

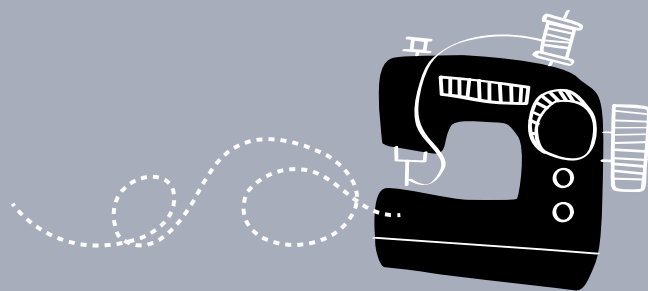

**Please read the following general instructions before starting your project.**

### How to choose the correct size

Children's pattern sizes are primarily chosen according to the child's height, and the pattern measurements are then adjusted to correspond to the child's other body measurements. Take the measurements on top of thin underwear and compare them with the size chart. You will find detailed instructions for taking measurements on the next page.

### How to find the pattern pieces on the pattern sheet

An overview of numbered, small-scale pattern pieces and a list of pattern pieces can be found next to the sewing instructions for each design. The appropriate pattern sheet is also stated. On the bottom edge of the pattern sheet, find the number with the correct color for the desired pattern piece and move your finger upward on the sheet until you locate the same number.

Trace the pattern on tissue paper, including all the necessary markings (e.g. grainlines, notches, pocket placements). The markings are also visible on the small-scale patterns next to the instructions. Make all adjustments to the pattern before cutting out the garment pieces.

### Patterns

The patterns include hem allowances, placket extensions and placket facings. When cutting out the garment pieces, add seam allowances of approx. 1 cm (depending on the fabric) to each edge of the pattern.

The position of the first or top button/buttonhole has been marked on the pattern. On blouses and shirts the top buttonhole on the front is approx. 4 cm below the neck seamline and the bottom buttonhole approx. 10 cm above the hemline. The rest of

the buttonholes should be placed at regular intervals (6...9 cm) between these points.

For reasons of clarity, some of the pattern markings (e.g. positions of Velcro tapes and buttons) have only been printed on the smallest-size pattern of the design. Copy these in the corresponding places on the pattern size of your choice, measuring the distance of each marking from the edge of the pattern piece. Large pattern pieces have been printed on the pattern sheet in two parts. Combine parts A and B before cutting out the garment pieces.

### Cutting

Lay out the pattern pieces on a double layer of fabric, observing the markings for grainlines and foldlines. Draw the seam allowances on the fabric with tailor's chalk.

If you only need to cut a piece out once, observe the pattern markings and cut either on a fold (e.g. back, collar) or from a single layer of fabric (e.g. pocket).

The measurements for garment pieces listed under the heading "Cut also" (e.g. belt loops, belts) already include seam allowances. When cutting out the garment, include allowances for fitting adjustments if necessary. Each design includes specific and detailed cutting instructions.

Garment sections to be interfaced are shaded in grey in the overview of small-scale pattern pieces. Knit and woven interfacings are cut on the grain, while non-woven interfacings may be cut in any direction as they do not have a grain. Interfacing pieces are generally cut adding the same amount of seam allowance (approx. 1 cm) as on pieces cut from fashion fabric. However, a smaller seam allowance may be used on interfacings for heavy-weight fabrics.

### Materials

Fabric requirements are based on a fabric width of 145...150 cm. Pre-shrink the fabric before cutting either by washing or by steaming it thoroughly. If you choose a different fabric from the one suggested in the magazine, allow for matching up fabric pattern and for cutting with nap when calculating the fabric requirement.

Choose the interfacing on the basis of the fashion fabric's color, quality, weight and care instructions.

Since the quality and stretch of elastics vary, check the elastic lengths before sewing.

If a zipper is not available in a desired length, buy a longer zipper and shorten it as shown in the illustration on pattern sheet D.

### Sewing

Read through the instructions before you start sewing. If you wish, baste and try the garment on before sewing. To make sewing easier, the instructions have been written on the basis of techniques used in the clothing industry. The terms "inner"/"outer" and "left"/"right" refer to the garment when worn.

Finish the construction seams of the garment after you have sewn them, even if the instructions do not specifically mention seam finish. You can either use a serger or a machine zig-zag stitch for finishing the seams. On knit fabrics, stitch the seams using a machine stretch-stitch or a serger. No separate seam finish is necessary. Seams inside a lined garment do not necessarily have to be finished.

On hems (e.g. at the garment's bottom edge or sleeve edges) the seam allowance is turned under and the hem is stitched close to the turned-under edge. The width of the hem and seam allowance is given in brackets; for example "stitch hem (2 cm + 1 cm)" means that the hem allowance is 2 cm and the seam allowance 1 cm.

Press the garment's seams as you go along and give the garment a final press when it is completed.

### Practical tips

**Gathering:** Adjust your sewing machine as follows: Decrease the upper thread tension and increase the stitch length (stitch length 4...5). Sew two rows of gathering stitches 0.5 cm apart from each other on the right side of the edge to be gathered, placing one row on the seamline and the other within the seam allowance. Leave long thread ends. Gather the fabric by pulling simultaneously on both bobbin threads and spreading the gathers between your fingers evenly over the required length. The gathered edge is stitched in place between the gathering stitches using a regular straight stitch.

**Easing:** Rows of ease-stitching are sewn as gathering stitches but the bobbin threads are pulled just enough to make the edge curve slightly (e.g. at set-in sleeve caps).

### Garments lined with knit

When the lining fabric is a knit and the fashion fabric a woven, cut the lining out with considerably narrower seam allowances to keep the lining from showing under the fashion fabric.



The designs, patterns, instructions, photos and articles in this magazine are protected under international copyright laws. Professional, industrial and commercial use of the material and manufacture under license is only possible under a written agreement with the copyright holder. For further information, contact us in writing at the following address: Studio Tuumat Oy, Rantavälikantie 33, FI-96300 Rovaniemi, Finland.

Copyright © Studio Tuumat Oy, Rovaniemi, Finland OTTOBRE design® or Studio Tuumat Oy has no obligation to compensate for possible financial losses resulting from misprints or other errors on the pattern sheet or in the instructions.

Copyright © Studio Tuumat Oy, Rovaniemi, Finland

# MEASURING THE CHILD

For taking the measurements, you'll need a tape measure and a length of firm tape that is placed round the waist. You can sew a waist tape for this purpose of a strip of cotton folded in four (finished width 1.5 cm). Place the tape horizontally round the child's waist and secure with a safety pin.

The child should stand upright with a relaxed posture with arms hanging free at the sides.

The measurements are taken on top of underwear (briefs and a light-weight undershirt) close to the body, yet not too tight. It is advisable to take the measurements in front of a mirror so that you can see the position of the tape measure behind the child.

## Height of the child:

With the child standing up with the back and heels against a wall, mark the height at the top of the head on the wall using a straight angle (e.g. a book). The height of the child is the distance measured from the floor to the marking.

## Chest measurement:

Horizontal measurement round the body with the tape measure running over the chest and shoulder blades.

## Waist measurement:

Measurement round the waist without the waist tape.

## Hip measurement:

Horizontal measurement round the seat (the fullest part of the bottom).

## Outseam length:

Distance from the waist to the floor measured from the lower edge of the waist tape.

## Inseam length:

Distance from the crotch to the floor when the child is standing legs slightly apart with the weight evenly on both feet.

## Shoulder width:

Distance from the base of the neck to the top of the arm.

## Sleeve length:

Distance from the top of the arm to the wrist measured over the elbow with the arm slightly bent.

## Back waist length:

Distance from the most prominent vertebra at the base of the neck to the lower edge of the waist tape.

The measurements in the chart are **taken on the body**. The patterns include the necessary **allowances for ease of movement**.

# SIZE CHARTS

## BABIES 50-92 cm

Height cm	50	56	62	68	74	80	86	92
1. Chest measurement	43	44.5	46	47.5	49	50.5	52	54
2. Waist measurement	46	47	48	49	50	51	52	53
3. Hip measurement	51	52	53	54	55	56	57	58
4. Sleeve length	18	20	22	24	26	28	30	32
5. Inseam length	15	18	21	24	27	30	33.5	37

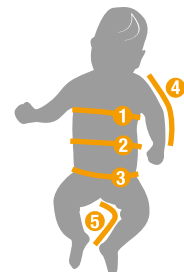

## TODDLERS 92-122 cm

Height cm	92	98	104	110	116	122
1. Chest measurement	54	56	58	60	62	64
2. Waist measurement	53	54	55	56	57	58
3. Hip measurement	58	60	62	64	66	68
4. Back waist length	22.5	24	25	26.5	28	29.5
5. Sleeve length	32	34	36	38	40	42
6. Outseam length	54	58	62	66	70	74
7. Shoulder width	8.0	8.4	8.8	9.2	9.6	10

## GIRLS AND BOYS

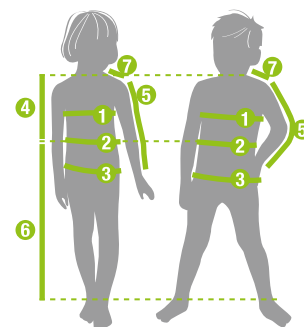

## GIRLS 128-170 cm

Height cm	128	134	140	146	152	158	164	170
1. Bust measurement	66	68	71	73	76	79	82	85
2. Waist measurement	59	61	63	64	66	68	70	72
3. Hip measurement	70	72	75	79	82	85	88	91
4. Back waist length	31	32.5	34	35.5	37	38.5	40	41.5
5. Sleeve length	44	46	48	50	52	54.5	57	59.5
6. Outseam length	78	82	86	90	93.5	97	100.5	104.5
7. Shoulder width	10.4	10.8	11.2	11.6	12	12.4	12.8	13.2

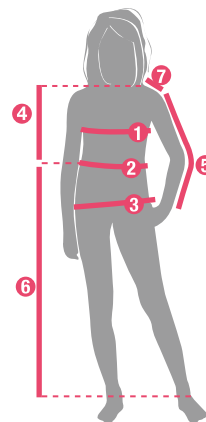

## BOYS 128-170 cm

Height cm	128	134	140	146	152	158	164	170
1. Chest measurement	66	68	71	75	78	81	84	87
2. Waist measurement	59	61	63	66	68	70	72	74
3. Hip measurement	70	72	75	78	81	84	87	90
4. Back waist length	31	32.5	34	35.5	37	39	41	43
5. Sleeve length	44	46	49	51.5	54	56.5	59	61.5
6. Outseam length	78	82	86	90	93.5	97	100.5	104
7. Shoulder width	10.4	10.8	11.2	11.6	12	12.5	13	13.5

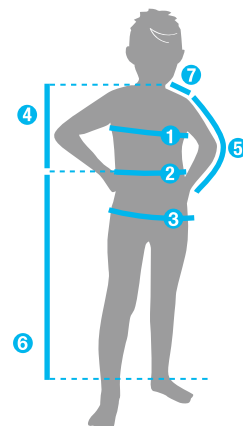

You can find these charts with measurements in inches on our website.

# I. Curry and Rock Grey bodysuits 50-56-62-68-74-80-86-92 cm

Pages 50, 53

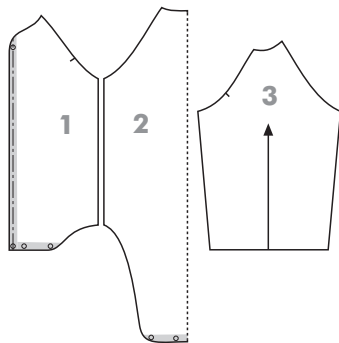

PATTERN PIECES	cut
1 front	2
2 back	1
3 sleeve	2

## PATTERN SHEET A red

### MATERIALS

- 50-50-55-55-55-60-60-65 cm printed cotton single jersey or striped organic-cotton single jersey (CO/EL), stretch/recovery 30%
- 10 cm ribbing (CO/EL), width 90 cm
- piece of interfacing, Vlieseline® G 785
- 9...11 small snap fasteners, ø 8 mm, Prym Mini

### CUTTING

Cut garment pieces from single jersey as indicated on list of pattern pieces, placing center-back of pattern on fabric fold and adding 7 mm seam allowances to raglan seams, sleeve-underarm seams and side seams. Do not add seam allowances to neckline, front edges of front panels, bottom edges of front and back panels and bottom edges of sleeves.

Cut 3.5 cm wide binding strips from ribbing for finishing neckline + front edges, bottom edge of front + back and bottom edges of sleeves (measure required lengths

of binding on pattern pieces). If you use a binder attachment on your coverstitch machine to attach the bindings, cut the binding strips in the width that fits the binder.

### SEWING

**Construction techniques:** Stitch seams with serger or with overedge stretch stitch on regular sewing machine. See general instructions for finishing edges with binding on p. 44.

**Preparation:** Mark position of snap fasteners on front edges (position of top

and bottom snaps has been marked on pattern; place the remaining 3...5 snaps at regular intervals between these). Cut narrow strips of interfacing for stabilizing snap areas and fuse them to wrong side of front edges of front panels as well as to wrong side of bottom edges of front and back panels (see edges shaded in grey on small-scale patterns).

**Joining:** Pin sleeves to front and back panels right sides together and stitch raglan seams. Finish bottom edges of sleeves with binding. Stitch sleeve underarm seams and side seams. Fold underarm seam allowances to one side and stitch them flat

across sleeve-edge bindings. Finish front edges and neckline with continuous binding. Finish garment's bottom edge with continuous binding, leaving a little extra at both ends of binding. Wrap ends of binding tightly over front edges to wrong side and stitch them in place. Trim excess binding off close to stitching.

**Finishing:** Attach snap fasteners, placing socket halves on front edge of right front panel and bottom edge of back panel and corresponding stud halves on front edge of left front panel and bottom edges of front panels.

# 2. Snowflakes sweatpants 50-56-62-68-74-80-86-92 cm

Page 50

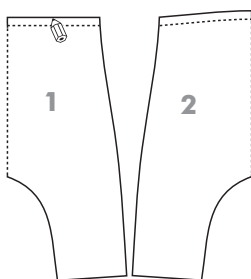

PATTERN PIECES	cut
1 pants front	1
2 pants back	1

## PATTERN SHEET A black

### MATERIALS

- 35-40-45-50-50-55-60-65 cm sweatshirt knit with soft, brushed reverse side (CO/EL), stretch/recovery 20%
- 43...50 cm elastic, width 15 mm

### CUTTING

Trace pattern piece for pants front observing pattern markings. Cut garment pieces from sweatshirt knit as indicated on list of pattern pieces, placing center-front and center-back edges of pattern pieces on fabric fold and adding 7 mm seam allowances to other edges.

### SEWING

**Construction techniques:** Stitch seams with serger or with overedge stretch stitch on regular sewing machine.

**Joining:** Pin pants front and back right sides together and stitch leg inseam. Stitch side seams. Turn pants right side out. Finish bottom edges of legs with serger rolled hem or with narrow, short zigzag; secure thread ends carefully. Bottom

edges of legs will curl nicely when the pants are worn.

**Waistline:** Measure and cut piece of elastic to fit the child (length of elastic = child's waist measurement minus 2...3 cm). Stitch ends of elastic together to form circle and mark elastic into quarters. Finish raw edge of waist casing allowance. Pin elastic to casing allowance, aligning quarter marks with pants side seams and

with center-front and center-back marks at waist edge. Stitch elastic to casing allowance by machine-basting across it at quarter marks. Fold casing allowance and elastic to wrong side of pants, pin casing in position and stitch it to pants along bottom edge of elastic with 3-thread coverstitch or with twin needle on regular sewing machine, stretching elastic evenly as you sew.

# 3. Bunny footed coverall 50-56-62-68-74-80-86 cm

Pages 48-51

### MATERIALS

- 60-65-70-75-80-85-90 cm soft sweatshirt knit with brushed reverse side (CO/EL), design A, or merino wool knit (WV), design B; both knits with 20% stretch/recovery
- invisible zipper, length 34-36-38-40-42-45-47 cm

- 85...110 cm fusible stay tape, width 12 mm, Vlieseline®
- Formband

### Design A:

- 5 cm ribbing (CO/EL)

### Design B:

- piece of white merino wool knit
- contrast-color merino wool yarn

PATTERN PIECES	cut
1 front	2
2 back	1
3 sleeve	2
4 crotch gusset	1
5 foot sole	2
6 knee patch, design B	2

## PATTERN SHEET A green

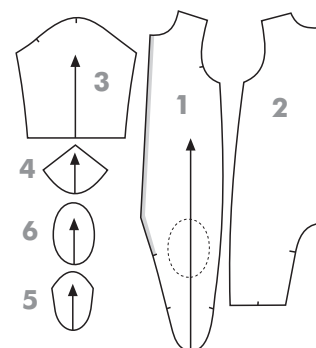

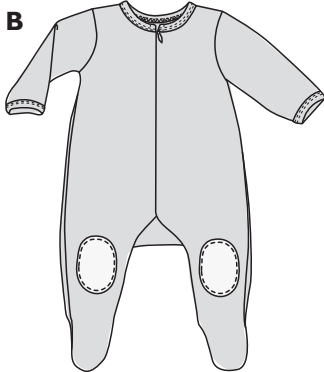

### CUTTING

**Design A:** Cut garment pieces from sweatshirt knit as indicated on list of pattern pieces, placing center-back of pattern on fabric fold and adding 7 mm seam allowances to all other edges except neckline and bottom edges of sleeves. Cut 3.5 cm wide binding strips from ribbing for finishing neckline and bottom edges of sleeves.

**Design B:** Cut knee patches from white and other garment pieces from grey merino wool knit as indicated on list of pattern pieces, placing center-back of pattern on fabric fold and adding 7 mm seam allowances to all other edges except neckline and bottom edges of sleeves. Cut 3.5 cm wide binding strips from grey merino wool knit for finishing neckline and bottom edges of sleeves.

**Both designs:** Cut 3 cm x 6 cm piece from sweatshirt knit (A) or white merino wool knit (B) for zipper shield to be placed under zipper stop at neckline.

### SEWING

**Construction techniques:** Stitch seams with serger or with overedge stretch stitch on regular sewing machine. Stitch zipper with straight stitch using invisible zipper foot. See general instructions for finishing edges with binding on p. 44.

**Preparation:** Cut two pieces of stay tape for stabilizing zipper placket edges (see edge shaded in grey on small-scale pattern; measure required length of tape on pattern). Trim tapes to width of 7 mm and fuse them to wrong side of placket seam allowances.

**Knee patches, design B:** Sew row of ease-stitching along outer edge of each knee patch. Make cardboard template with pattern piece for knee patch. Place knee patch on ironing board wrong side up. Lay template on wrong side of knee patch. Holding template and patch against ironing board, pull up bobbin thread of ease-stitching to turn seam allowance on outer edge of patch over edge of template to wrong side. Steam seam allowance in position and allow knee patch to dry for a short while. Remove template and trim seam allowance to 5 mm. Pin knee patches to front legs as marked on pattern and stitch them in place by hand with short running stitches, using merino wool yarn.

**Joining:** Pin and stitch foot soles to back panel. Stitch crotch gusset to back panel. Pin shoulder edges of front panels to back panel right sides together and stitch shoulder seams. Finish bottom edges of sleeves with binding. Stitch sleeves to armholes. Pin front and back panels right sides together. Stitch sleeve underarm seams and side seams

and continue stitching around toe ends of foot soles and along leg inseam edges, ending stitching on right leg at center-front corner of crotch gusset and on left leg at notch for zipper placket. Fold underarm seam allowances to one side and stitch them flat across sleeve-edge bindings.

Finish neckline with binding. Finish raw zipper-placket edges on front panels by serging or zigzagging. Open zipper: Pin and stitch zipper tapes to placket edges right sides together, aligning top end of zipper coil with top edge of neckline binding. Wrap top ends of zipper tapes over edge of neckline binding to wrong side, pin them in position and stitch them in place across neckline binding.

**Finishing:** Fold zipper shield in half width-wise, right sides together, and stitch its side edges. Turn shield right side out and serge or zigzag its open edges together. Pin and stitch shield to garment's placket-edge seam allowance, placing it under top stop of zipper.

## 4. Stars in Blue Sky dress

50-56-62-68-74-80-86-92 cm

Page 50

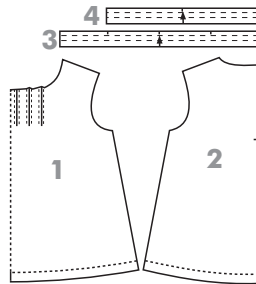

### PATTERN PIECES

PATTERN PIECES	cut
1 front	1
2 back	1
3 neckline facing*	1
4 armhole facing*	2

### PATTERN SHEET A lilac

### MATERIALS

- 45-45-45-50-55-55-55-60 cm printed organic-cotton single jersey (CO), stretch/recovery 10%  
- 1 sew-on snap fastener, ø 6 mm

### CUTTING

Cut garment pieces from single jersey as indicated on list of pattern pieces, placing center-front and center-back edges of pattern pieces on fabric fold and adding 7 mm seam allowances to other edges. \*Pattern pieces for facings include seam allowances.

### SEWING

**Construction techniques:** Stitch seams

with serger or with overedge stretch stitch on regular sewing machine. Stitch tucks, edges of back slit as well as neckline and armhole facings with straight stitch, and stitch bottom hem with 3-thread coverstitch or with twin needle on regular sewing machine.

**Joining:** Fold front panel wrong sides together along each pattern marking for tuck foldline and press. Stitch tucks 5 mm from fold. Fold and press tucks toward

the left. Slash slit on back panel as marked on pattern and stitch narrow hems along edges of slit. Place edges of slit right sides together and stitch small dart at the bottom of slit.

Pin front and back right sides together and stitch shoulder seams. Stitch neckline facing to neckline right sides together with 7 mm seam allowance. Trim neckline seam allowances slightly and understitch them to facing close to seamline. Fold

facing to wrong side of neckline, turn seam allowance at its free edge and end under and stitch it to neckline close to its turned-under edge. Finish armholes with facing in the same way as neckline, without turning ends of facing under.

Stitch side seams. Press side seam allowances toward back panel and stitch them flat across armhole facings. Fold up, press and stitch bottom hem as marked on pattern. Sew snap fastener at neckline.

## 5. Baa-Baa Little Lamb wool-knit overalls

50-56-62-68-74-80-86-92 cm

Pages 52-53

### MATERIALS

- 40-45-50-55-60-60-65-70 cm garter stitch knit (VV), width 125 cm  
- 20 cm merino wool single jersey (VV), width 145 cm  
- contrast-color merino wool yarn

- 2 wooden toggle buttons, length 25 mm  
- 25-25-26-26-27-27-28-28 cm clear elastic tape (Framilon®) or regular elastic, width 8 mm  
- piece of interfacing for stabilizing buttonholes

### CUTTING

Cut pants front and back from garter stitch knit as indicated on list of pattern pieces, placing center-front and center-back edges of pattern pieces on fabric fold and adding 10 mm seam allowances to all other edges except top edges of

pants panels and bottom edges of legs. Cut the other garment pieces from merino wool single jersey as indicated on list of pattern pieces, adding 10 mm seam allowances to knee patches. \*Pattern pieces marked with an asterisk include seam allowances. >>>



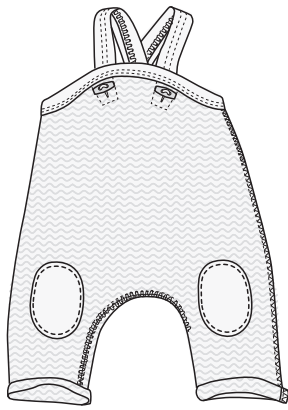

## SEWING

**Construction techniques:** Stitch side seams and leg inseam with straight stitch, press seams open and topstitch them with 5-thread coverstitch or with suitable decorative stitch on regular sewing machine (e.g. honeycomb stitch).

**Preparation:** Stitch knee patches to front legs, following instructions for design 3B. Fuse piece of interfacing to wrong side of each reinforcing piece. Pin reinforcing pieces to top edge of pants front as marked on pattern, wrong sides together, and stitch them in place close to edge with straight stitch. Stitch buttonholes at top edge of pants front as marked on pattern. Stitch piece of clear elastic tape or regular elastic to wrong side of seam allowance at top edge of pants back, stretching elastic slightly as you sew.

**Joining:** Pin pants front and back right sides together and stitch leg inseam. Stitch side seams. Turn pants right side out. Finish bottom edges of legs with serger rolled hem or with narrow, short zigzag; secure thread ends carefully. Bottom edges of legs will curl nicely when the pants are worn.

Stitch ends of binding together to form circle. Copy pattern markings for center-front and center-back points as well as for one side seam on binding (seam on binding will be aligned with the other side seam). Pin one edge of binding to top edge of pants right sides together and stitch with 10 mm seam allowance. Wrap

binding over top edge to wrong side, pin its free edge to pants carefully and stitch from right side of pants with 3-thread coverstitch or with twin needle on regular sewing machine.

**Shoulder straps:** Fold and press each shoulder strap in three as marked on pattern, so that edge along the middle of strap is placed on the outside. Stitch along the middle of strap with 5-thread coverstitch. Serge or zigzag ends of straps. Pin ends of shoulder straps to wrong side of top edge of pants back, placing them on each side of center-back mark approx. 2 cm apart, and stitch them in place along rows of stitching on binding. Stitch across straps also along top edge of binding.

Cross shoulder straps approx. 10 cm above top edge of pants back, pin them in position and stitch them together by hand with a few stitches sewn in the same place, using merino wool yarn. Sew buttons at free ends of straps using merino wool yarn.

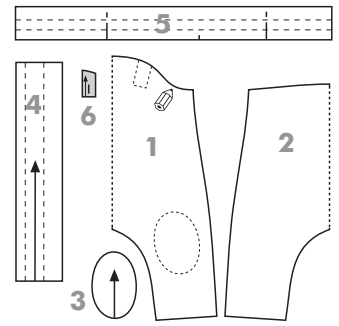

PATTERN PIECES	cut
1 pants front	1
2 pants back	1
3 knee patch	2
4 shoulder strap*	2
5 binding*	1
6 reinforcement piece*	2

PATTERN SHEET **A** black

## 6. Wooly Star jacket

50-56-62-68-74-80-86-92 cm

Pages 52-53

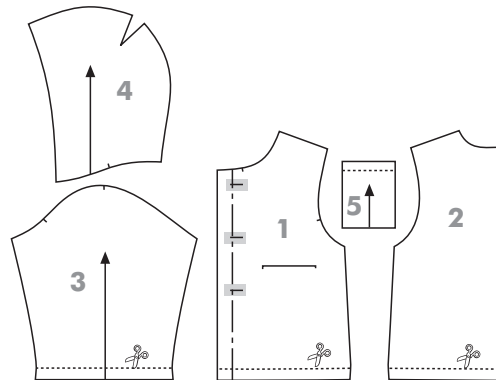

PATTERN PIECES	cut	
	Shell	Lining
1 front	2	2
2 back	1	1
3 sleeve	2	2
4 hood	2	2
5 pocket	2	-

PATTERN SHEET **A** orange

## MATERIALS

- 60-60-70-75-80-80-85-95 cm garter stitch knit (VV), width 125 cm
- 55-60-65-65-65-70-70-75 cm printed organic-cotton single jersey (CO), stretch/recovery 10%
- contrast-color merino wool yarn
- 3...4 wooden toggle buttons, length 25 mm
- interfacing for stabilizing buttonholes

## CUTTING

**Shell:** Cut shell pieces from wool knit as indicated on list of pattern pieces, placing center-back of pattern on fabric fold and adding 10 mm seam allowances to other edges.

**Lining:** Fold away hem allowances on pattern pieces for front, back and sleeve.

Cut lining pieces from cotton single jersey as indicated on list of pattern pieces, placing center-back of pattern on fabric fold and adding 10 mm seam allowances to all other edges except bottom-hem edges of front and back panels and bottom edges of sleeves.

## SEWING

**Construction techniques:** Stitch shoulder seams and armhole seams on shell as well as top/back seam of shell hood with straight stitch, press seams open and topstitch them with coverstitch. Stitch the other seams on shell as well as all seams on lining with straight stitch. Stitch coverstitching with 5-thread coverstitch or use suitable decorative stitch on regular sewing machine (e.g. honeycomb stitch).

**Preparation:** Fuse interfacing to areas of lining front panels shaded in grey on small-scale patterns. Stitch hems at opening edges of pockets with 5-thread coverstitch. Turn seam allowances at other pocket edges to wrong side, pin pockets to shell fronts as marked on pattern and

stitch them in place close to edge.

**Joining shell:** Stitch and topstitch shoulder seams. Stitch sleeves to armholes and topstitch seams. Stitch sleeve underarm seams and side seams. Steam underarm and side seams open.

**Joining lining:** Stitch shoulder seams. Stitch sleeves to armholes. Stitch sleeve underarm seams and side seams. Press each seam on lining open straight after stitching it.

**Hood:** Stitch darts on shell and lining hood panels. Stitch and topstitch top/back seam of shell hood. Stitch top/back seam of lining hood. Steam seams on hood sections. Place shell and lining hoods within one another right sides together and stitch their face edges together. Pull hood sections apart and understitch face-edge seam allowances to lining hood close to seamline. Place shell and lining hoods within one another wrong sides together and machine-baste their bottom edges together. Steam face edge of hood. Machine-baste hood to shell's neckline right sides together, aligning its bottom front

corners with pattern markings on shell.

**Joining shell and lining:** Pin and stitch front edges of shell and lining right sides together, aligning bottom-hem edge of lining with bottom-hem foldline on shell. Understitch front-edge seam allowances to lining close to seamline. Pin and stitch necklines of shell and lining right sides together, with hood in between. Trim neckline seam allowances slightly and clip them along curves if necessary. Turn garment right side out. Insert lining sleeves into shell sleeves. Align bottom edges of lining sleeves with hem foldlines on shell sleeves, and fold up and pin hems. Stitch sleeve-edge hems with 5-thread coverstitch. Pin bottom-hem edge of lining to bottom-hem foldline of shell, fold up and pin hem, and stitch it with 5-thread coverstitch.

**Finishing:** Stitch buttonholes on right front panel as marked on pattern. Sew buttons on left front panel, using merino wool yarn.

## 7. Wind Stripes balaclava hood

head circumference 38-40-42-44-46-48-50 cm

Pages 48-49

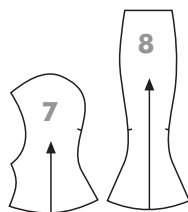
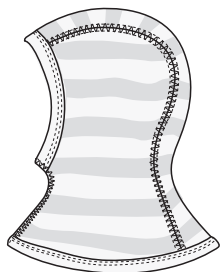

### PATTERN PIECES cut

7 side panel	2
8 center panel	1

### PATTERN SHEET **A** black

### MATERIALS

- 45...50 cm striped organic-cotton single jersey (CO/EL), stretch/recovery 30%
- 5 cm ribbing (CO/EL)

### CUTTING

Cut hood pieces from single jersey as indicated on list of pattern pieces, adding 7 mm seam allowances to all edges and aligning stripes at pattern markings. Cut 3.5 cm wide binding strips from ribbing for finishing face edge and bottom edge

of hood. If you use a binder attachment on your coverstitch machine to attach the bindings, cut the binding strips in the width that fits the binder.

### SEWING

**Construction techniques:** Stitch seams

with straight stitch, press them open and topstitch them with 5-thread coverstitch or with suitable decorative stitch on regular sewing machine (e.g. honeycomb stitch). See general instructions for finishing edges with binding on p. 44.

**Joining:** Pin and stitch side panels to

center panel. Topstitch seams. Finish face edge and bottom edge of hood with binding. Stitch and topstitch center-front seam. Secure thread ends carefully. Stitch horizontal rows of back-and-forth stitching with straight stitch at both ends of seam.

## 8. Talvikukka tunic

62-68-74-80-86-92 cm

Page 59

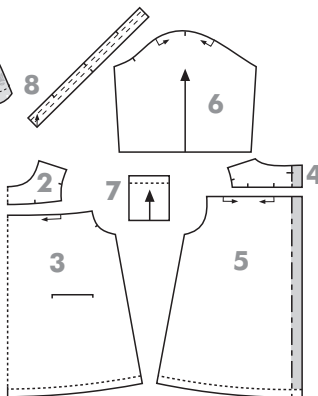

### PATTERN PIECES cut

2 front yoke	1
3 front	1
4 back yoke	2
5 back	2
6 sleeve	2
7 pocket	2
8 neckline facing*	1

### PATTERN SHEET **A** blue

### MATERIALS

- 60-65-70-70-75-80 cm lightweight printed organic-cotton poplin (CO)
- 5 cm interfacing, Vlieseline® H 180
- 40-41-42-43-44-45 cm elastic, width 8 mm
- 5 small buttons, ø 10 mm

### CUTTING

Cut garment pieces from poplin as indicated on list of pattern pieces, placing center-front edges of pattern pieces on fabric fold and adding 10 mm seam allowances to other edges. \*Pattern piece for neckline facing includes seam allowances.

### SEWING

**Construction techniques:** Stitch seams with straight stitch and finish them with serger or zigzag stitch. Topstitch seams close to seamline.

**Preparation:** Fuse interfacing to placket facings on back panels and back yokes (see areas shaded in grey on small-scale patterns). Turn placket facings to wrong side of back panels and back yokes as marked on pattern and press.

**Pockets:** Fold, press and stitch hems at opening edges of pockets as marked on pattern. Turn and press seam allowances at other pocket edges to wrong side. Pin and stitch pockets to front panel as marked on pattern.

**Joining:** Sew gathering stitches along top edges of front and back panels as marked on pattern and gather edges to fit yokes. Pin front yoke to front panel right sides together and stitch yoke seam. Fold seam allowances toward yoke and topstitch seam. Stitch and topstitch yoke seams on back in the same way. Stitch shoulder seams.

**Neckline:** Fold placket facings on back yokes onto right side of yokes, turn seam allowances at their outer edges in position and stitch neckline edges of facings to

yokes. Pin and stitch one edge of neckline facing to neckline right sides together, with ends of facing slightly overlapping placket facings. Trim neckline seam allowances slightly and clip them along curves. Turn back neckline corners right side out. Understitch neckline seam allowances to neckline facing. Fold neckline facing to wrong side of neckline, turn seam allowance at its free edge under, pin it to neckline and stitch it in place close to its turned-under edge.

**Sleeves:** Sew gathering stitches along sleeve caps as marked on pattern and gather sleeves to fit armholes. Pin and stitch sleeves to armholes right sides together. Fold seam allowances toward body of garment and topstitch seams. Stitch sleeve underarm seams and side seams.

Cut elastic into two equal-length pieces and stitch ends of each piece together to form circles. Finish raw bottom edges of sleeves. Machine-baste circles of elastic to seam allowances at bottom edges of sleeves, stretching them slightly as you sew. Turn sleeve-edge seam allowances to seam allowances at wrong side and stitch sleeve edges along edge of elastic.

**Finishing:** Fold up, press and stitch bottom hem (1 cm + 2 cm). Turn seam allowances at outer edges of placket facings to wrong side, and pin and stitch facings to back panels. Stitch buttonholes on left back panel, placing top buttonhole as marked on pattern and the rest at regular 6...7 cm intervals. Sew buttons on right back panel.

## 9. Nöpö bloomers

62-68-74-80-86-92 cm

Page 59

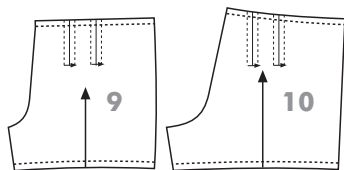

### PATTERN PIECES

	cut
9 pants front	2
10 pants back	2

### PATTERN SHEET A blue

### MATERIALS

- 35...40 cm lightweight printed organic-cotton poplin (CO)
- 100...120 cm elastic, width 15 mm

### CUTTING

Cut garment pieces from poplin as indicated on list of pattern pieces, adding 10 mm seam allowances to all edges.

### SEWING

**Construction techniques:** Stitch seams with straight stitch and finish them with serger or zigzag stitch.

**Joining:** Pin and stitch pleats at waist edges of pants fronts and backs as marked on pattern. Fold pleat underfolds toward center-front and center-back and press waist edges. Pin pants fronts and backs right sides together and stitch leg inseams. Stitch crotch seam. Stitch side seams. Press seams.

**Waistline and bottom edges of legs:** Finish raw waist edge and bottom edges

of legs. Measure and cut piece of elastic to fit the child's waist (length of elastic = child's waist measurement minus 2...3 cm) and stitch its ends together to form circle. Mark elastic into quarters. Pin elastic to waist casing allowance, aligning quarter marks with center-front, center-back and side seams, and machine-baste elastic to casing allowance at these points. Fold casing allowance with elastic to wrong

side and stitch it in place along outer edge of elastic, stretching elastic as you sew.

Measure and cut two pieces of elastic to fit the child's thigh circumference and stitch ends of each elastic together to form circles. Mark elastics into halves and finish bottom edges of legs with elastics in the same way as waistline.

## 10. Hopeahelma special-occasion dress 92-98-104-110-116-122-128 cm

Page 58

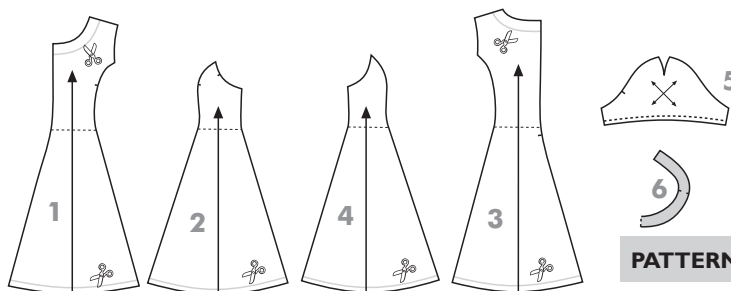

### MATERIALS

- 105-110-115-120-130-145-155 cm silver-coated linen-blend fabric (LI/CV/PES/PU), width 125 cm
- 90-95-100-110-125-130-145 cm

- viscose lining fabric (CV), width 145 cm
- 20 cm interfacing, Vlieseline® G 785
- invisible zipper, length 25-25-30-30-35-35-35 cm

### PATTERN PIECES

	Shell	Lining
1 front	2	✂ 2
2 side front	2	✂ 2
3 back	2	✂ 2
4 side back	2	✂ 2
5 sleeve	2	-
6 shaped facing	1	-

### PATTERN SHEET B black

### CUTTING

**Shell:** Cut shell pieces and shaped facing from linen-blend fabric as indicated on list of pattern pieces, adding 10 mm seam allowances to all edges. Note that sleeves are cut on the bias.

**Lining:** Prepare the pattern as follows before cutting the lining: Cut off portions of shaped facing from pattern pieces for front and back and shorten hemlines of all pattern pieces by 2 cm (see markings on small-scale patterns). Cut lining pieces from lining fabric as indicated on list of pattern pieces, adding 10 mm seam allowances to all edges.

### SEWING

**Construction techniques:** Stitch seams with straight stitch and finish them with serger or zigzag stitch. Note that princess seams are only finished from waistline (marked with dashed line on pattern) to bottom hem. Clip seam allowances on front and back panels along curved portions of princess seams after stitching seams.

**Stabilizing:** Fuse interfacing to shaped facing.

**Joining shell:** Finish raw center-front edges of front panels. Pin front panels right sides together and stitch center-front seam. Press seam open. Stitch side fronts to front panels (= princess seams), finish seam allowances together and press them gently toward front panels. Stitch side backs to back panels in the same way as princess seams on front.

Pin front and back panels right sides together and stitch shoulder seams. Press seams open. Stitch side seams. Finish seam allowances together and press them toward garment's back. Stitch darts at sleeve caps and press them toward sleeve fronts. Stitch underarm seams of sleeves. Finish raw bottom edges of sleeves. Fold up, press and stitch hems at bottom edges of sleeves. Pin and stitch sleeves to armholes.

**Joining lining:** Pin front panels right sides together and stitch center-front seam. Stitch princess seams on front and back. Pin front and back right sides together

and stitch shoulder seams and side seams. Pin and stitch shaped facing to neckline of lining right sides together. Press seam allowances toward lining. Press all seams on lining. Finish raw armhole edges and stitch narrow hems on them.

**Joining shell and lining:** Finish raw center-back edges of shell and lining. Pin shell and lining right sides together and stitch neckline seam, starting and ending stitching 4 cm away from center-back edges. Clip neckline seam allowances along curves and trim them if necessary. Understitch neckline seam allowances to shaped facing close to seamline.

**Zipper:** Open zipper. Pin one zipper half to center-back edge of shell right sides together and stitch it in place using invisible zipper foot. Stitch the other zipper half to the other center-back edge of shell in the same way. Open zipper on shell. Turn shell and lining inside out. Pin and stitch left zipper-placket edge of lining to placket edge of shell, right sides together and with zipper in between. Place stitching 5 mm away from stitching line that attach-

es zipper and stop stitching 3 cm before notch for placket on lining. Stitch right zipper-placket edge of lining to placket edge of shell in the same way. The bottom of the zipper placket on the lining is thus not attached to the shell in order to allow ease for sitting.

Turn all center-back seam allowances at top end of zipper placket onto shaped facing and pin and stitch rest of neckline seam on each side of placket. Trim seam allowances at top corners of placket and trim off excess ends of zipper tapes. Turn garment right side out and turn top corners of placket in position. Stitch center-back seams of shell and lining from notch for zipper placket to bottom hem. Press center-back seams open and press zipper placket gently.

**Finishing:** Attach armholes of lining to shoulder seams and side seams of shell with a few hand stitches. Stitch hem (5 mm + 5 mm) at bottom edge of lining. Finish raw bottom-hem edge of shell. Stitch narrow hem at bottom edge of shell.

# 11. Pupuliini furry jumpsuit

92-98-104-110-116-122-128 cm

Pages 5, 18-19

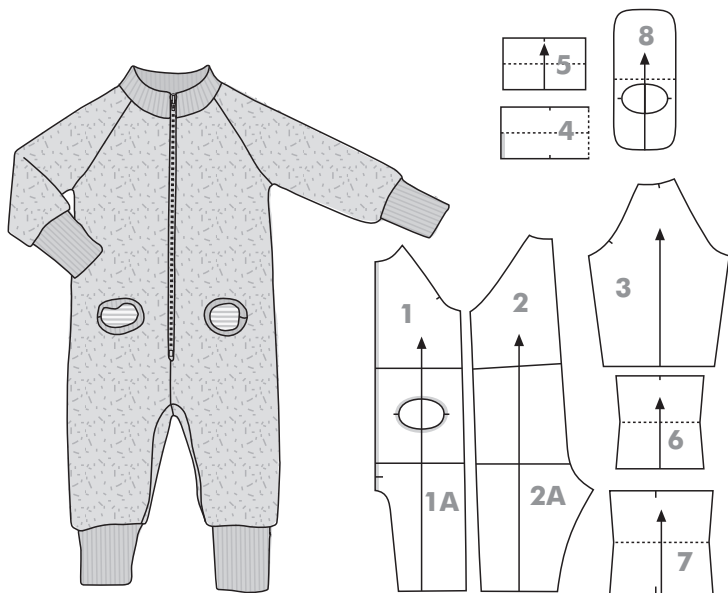

## MATERIALS

- 70-80-85-90-95-105-110 cm short-pile faux fur (CO/PES), stretch/recovery 15%
- 45-50-50-50-55-55-55 cm striped cotton single jersey (CO/EL) for lining
- 40-45-45-50-50-55-55 cm stretchy knit lining fabric (PES/PA) for lining
- 35...45 cm ribbing (CO/EL), width 90 cm, or 20 cm ribbing, width 140 cm
- 10 cm interfacing, Vlieseline® G 785
- 90...110 cm fusible stay tape, width 12 mm, Vlieseline® Formband
- zipper, length 40-40-45-45-45-50-50 cm

## PATTERN PIECES cut

<i>Faux fur</i>	
<b>1+1A</b> front	2
<b>2+2A</b> back	2
<b>3</b> sleeve	2
<i>Ribbing</i>	
<b>4</b> collar	1
<b>5</b> pocket band	2
<b>6</b> sleeve cuff	2
<b>7</b> bottom-leg cuff	2
<i>Striped jersey</i>	
<b>1</b> upper front panel	2
<b>2</b> upper back panel	2
<b>8</b> pocket bag	2
<i>Knit lining fabric</i>	
<b>1A</b> lower front panel	2
<b>2A</b> lower back panel	2
<b>3</b> sleeve	2

## PATTERN SHEET B red

## CUTTING

**Shell:** Join pattern pieces **1+1A** and **2+2A** before cutting. Cut shell pieces from faux fur and ribbing as indicated on list of pattern pieces, placing center-back edge of pattern piece for collar on fabric fold and adding 10 mm seam allowances to other edges.

**Lining:** Cut pocket bags as well as upper front and back panels from striped single jersey, and cut lower front and back panels as well as sleeves from knit lining fabric, adding 10 mm seam allowances to all edges.

## SEWING

**Construction techniques:** Stitch seams with serger or with straight stretch stitch on regular sewing machine. Stitch pockets, pocket bands, sleeve cuffs, bottom-leg cuffs and zipper in place with straight stitch. Use zipper foot for stitching zipper.

**Stabilizing:** Fuse pieces of interfacing to wrong side of pocket opening areas on shell front panels. Fuse pieces of stay tape to center-front edges of collar and

shell front panels. See areas and edges shaded in grey on small-scale patterns.

**Pockets:** Stitch side edges of each pocket band right sides together to form circles. Fold bands in half wrong sides together. Cut pocket openings on shell front panels as marked on pattern. Pin and stitch pocket bands to pocket openings right sides together, placing seam on band at edge of pocket opening closest to garment's side seam. Pin and stitch pocket bags to pocket openings, right sides together and with pocket bands in between. Fold pocket bags to wrong side. Fold pocket bags in half right sides together and stitch their side and bottom edges.

**Joining shell:** Pin back panels right sides together and stitch center-back seam. Pin front panels right sides together and stitch center-front seam from crotch to notch for zipper placket. Stitch leg inseams. Pin sleeves to front and back panels and stitch raglan seams. Stitch sleeve underarm seams and side seams. Stitch one edge of collar to neckline right sides together. Leave shell inside out.

Stitch side edges of each sleeve cuff and bottom-leg cuff together to form circles. Fold cuffs in half wrong sides together. Place cuffs within shell sleeves and legs right sides together, aligning midpoints and seams. Stitch cuffs in place with straight stitch, stretching them as you sew.

**Joining lining:** Stitch upper and lower front panels as well as upper and lower back panels right sides together. Stitch center-back seam. Stitch center-front seam from crotch to notch for zipper placket. Stitch leg inseams. Pin sleeves to front and back panels and stitch raglan seams. Stitch sleeve underarm seams and side seams, leaving 15 cm opening for turning in side seam along one leg.

**Joining shell and lining:** Open zipper and stitch it to center-front edges of shell right sides together; align top end of zipper teeth with foldline on collar and turn top ends of zipper tapes diagonally away from zipper teeth. Turn shell and lining inside out. Stitch free edge of collar to neckline of lining right sides together.

With collar between shell and lining, pin and machine-baste necklines of shell and lining together, stitching within seam allowances; start and end stitching approx. 5 cm away from center-front edges.

Pin and stitch bottom edges of shell and lining sleeves right sides together, with sleeve cuffs in between. Note! Shell and lining sleeves are not placed within one another but their bottom edges are brought end to end and then stitched together. Stitch bottom edges of legs of shell and lining together in the same way. Turn garment right side out by pushing your hand between center-front edges of shell and lining and pulling sleeves and legs out one at a time.

Then push your hand through opening for turning, take hold of center-front edges of shell and lining, and pin and stitch edges together, with zipper in between. Secure side seam allowances of shell and lining together at armpits with a few hand stitches. Close opening for turning.

# 12. Huppunen bunny hood head circumference 48-50-52-54 cm

Pages 5, 18-19

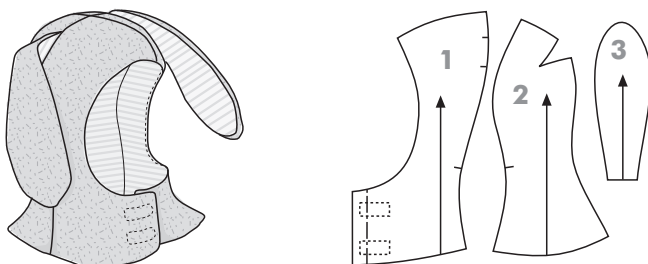

## PATTERN PIECES cut

<b>1</b> side front panel	2+2
<b>2</b> side back panel	2+2
<b>3</b> ear	2+2

## PATTERN SHEET D orange

## MATERIALS

- 40...45 cm short-pile faux fur knit (CO/PES), stretch/recovery 15%
- 40...45 cm striped cotton single jersey (CO/EL) for lining
- 8 cm Velcro loop tape and 10 cm Velcro hook tape, width 18 mm



## CUTTING

Cut exterior hood pieces from faux fur and lining pieces from striped single jersey, adding 10 mm seam allowances to all edges on exterior pieces and 7 mm seam allowances to all edges on lining pieces.

## SEWING

**Construction techniques:** Stitch seams with straight stitch. Stitch both hood exterior and hood lining with 10 mm seam allowances to make lining slightly smaller than hood exterior.

**Ears:** Pin ear pieces right sides together in pairs (exterior + lining) and stitch their

long edges together. Trim seam allowances at tips of ears and turn ears right side out. Steam ears. Machine-baste ears along their open edges to exterior side-front panels as marked on pattern, placing right side of ear lining against right side of side front panel.

**Joining:** Stitch darts on exterior and lining side-back panels and press dart seams open. Pin exterior side-front and side-back panels right sides together and stitch side seams. Press seams open. Pin hood exterior halves right sides together and stitch top/back seam. Stitch side seams of hood lining in the same way and press seams open. Stitch top/back seam of lining,

leaving small opening for turning in back seam, close to bottom edge of hood. Press top/back seams of hood exterior and lining open.

## Joining hood exterior and lining:

Place hood exterior and hood lining within one another right sides together and pin and stitch their face edges together. Clip seam allowances along curves and understitch face-edge seam allowances to lining close to seamline. Stitch bottom edges of hood exterior and hood lining together (do not stitch vertical front edges yet) and understitch seam allowances to lining close to seamline. Turn hood right side out. Pull front edges of hood out through

opening for turning and stitch front edges of hood exterior and lining together. Push front edges back and turn them right side out. Close opening for turning. Steam edges of hood.

**Finishing:** Cut each Velcro tape into two equal-length pieces and round corners of pieces slightly. Stitch hook tapes to left front edge of hood on exterior side and loop tapes to right front edge on lining side as marked on pattern.

# 13. Side Stripe leggings

92-98-104-110-116-122-128-134-140 cm

Pages 4, 10-11, 16-17

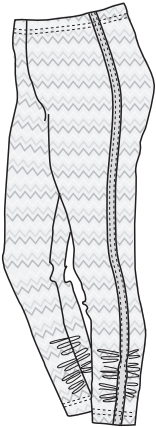

## CUTTING

Join pattern pieces **1+1A** before cutting. Cut garment pieces from single jersey as indicated on list of pattern pieces, adding 7 mm seam allowances to all edges.

## SEWING

**Construction techniques:** Stitch seams with serger or with overedge stretch stitch on regular sewing machine. Stitch hems and waist casing with 3-thread coverstitch or with twin needle on regular sewing machine.

**Preparation:** Sew two rows of gathering stitches in the middle of each pants panel as marked on pattern, placing them 7 mm apart. Pull up bobbin threads of gathering stitches and gather portion between pattern markings to length of 10 cm. Cut grosgrain ribbon into two equal-length pieces. Pin grosgrain ribbons to pants panels as marked on pattern and stitch them in place along both edges with straight stitch, stretching both ribbon and pants panel slightly as you sew to produce elastic rows of stitching. Steam ribbon areas to shrink them back to their correct length.

**Clear elastic tapes:** Cut clear elastic tape into two equal-length pieces and machine-baste pieces to right side of leg-inseam seam allowances on pants front, placing them between pattern markings and stretching them as you sew to gather edges slightly. On finished garment, clear elastic tapes will be concealed between seam allowances.

**Joining:** Fold up, press and stitch hems at bottom edges of legs as marked on pattern. Fold pants panels in half right sides together and stitch leg inseams. Fold seam allowances to one side and stitch them flat across bottom-leg hems. Place pants legs within one another right sides together and stitch crotch seam; leave 15 mm opening across waist casing allowance at center back for inserting elastic.

**Waistline:** Fold, press and stitch waist casing as marked on pattern. Measure and cut piece of elastic to fit the child and insert it into waist casing. Stitch ends of elastic together and close opening on casing.

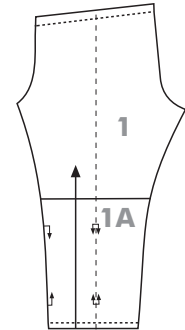

## MATERIALS

- 70-75-80-80-85-90-95-100-105 cm printed cotton single jersey (CO/EL), stretch/recovery 30%
- 120...170 cm stretch grosgrain ribbon, width 10 mm
- 50...58 cm elastic, width 20 mm
- 20 cm clear elastic tape, width 5 mm, Framilon®

**PATTERN PIECES** cut

**1+1A** pants panel 2

**PATTERN SHEET B** lilac

# 14. Ruusunen jersey dress

92-98-104-110-116-122-128 cm

Pages 5, 16-17

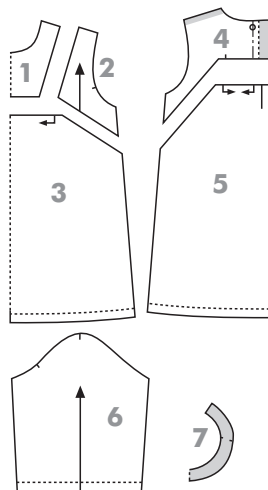

**PATTERN PIECES** cut

- |                          |   |
|--------------------------|---|
| <b>1</b> front yoke      | 1 |
| <b>2</b> side front yoke | 2 |
| <b>3</b> front           | 1 |
| <b>4</b> back yoke       | 2 |
| <b>5</b> back            | 1 |
| <b>6</b> sleeve          | 2 |
| <b>7</b> shaped facing   | 1 |

**PATTERN SHEET B** green

## MATERIALS

- 65-70-80-85-90-95-100 cm printed double-face jersey (CV/PES/EL), stretch/recovery 25%
- 25 cm striped cotton single jersey (CO/EL), stretch/recovery 30%
- 20 cm interfacing, Vlieseline® G 785
- snap fastener, ø 10 mm

## CUTTING

Cut side front yokes from striped single jersey and other garment pieces from printed double-face jersey as indicated on list of pattern pieces, placing center-front and center-back edges of pattern pieces on fabric fold and adding 10 mm seam allowances to other edges.

## SEWING

**Construction techniques:** Stitch yoke and neckline seams with straight stitch. Stitch the other seams with serger or with overedge stretch stitch on regular sewing machine. Stitch hems with 3-thread coverstitch or with twin needle on regular sewing machine.

**Stabilizing:** Fuse interfacing to back yokes and shaped facing (see areas shaded in grey on small-scale patterns). Finish raw outer edges of placket facings on back yokes as well as raw outer edge of shaped facing. >>>

**Front:** Pin front yoke and side front yokes right sides together and stitch seams with straight stitch. Finish seam allowances together, fold them toward front yoke and topstitch seams close to seamline. Sew gathering stitches along top edge of front panel as marked on pattern and gather edge to fit yoke. Stitch yoke to front panel, fold seam allowances toward yoke and topstitch seam close to seamline.

**Back:** Slash slit to the right of center-back line on back panel as marked on pattern. Stitch narrow hems at edges of

slit. Place edges of slit right sides together and stitch small dart at bottom of slit. Sew gathering stitches along top edges of back panel as marked on pattern and gather edges to fit back yokes. Stitch yokes to back panel, aligning center-back mark on back panel with center-back mark on left yoke and right edge of slit on back panel with center-back mark on right yoke. Fold placket facings to right side of back yokes and stitch their bottom edges to yoke seams. Turn corners right side out. Fold seam allowances of yoke

seams toward yokes and topstitch seams close to seamline.

**Joining:** Stitch shoulder seams. Stitch ends of shaped facing to outer edges of placket facings on back yokes, right sides together. Fold placket facings to right side of yokes, pin shaped facing to neckline right sides together and stitch neckline seam. Trim neckline seam allowances to approx. 5 mm and clip them along curves. Understitch neckline seam allowances to shaped facing close to seamline. Attach outer edge of shaped facing to garment's

shoulder seam allowances with a few hand stitches.

Fold up, press and stitch hems at bottom edges of sleeves. Stitch sleeves to armholes. Stitch sleeve underarm seams and side seams. Fold underarm seam allowances to one side and stitch them flat across sleeve-edge hems. Fold up, press and stitch bottom hem.

**Finishing:** Attach snap fastener to back placket as marked on pattern.

## 15. Steampunk

jersey T-shirt 92-98-104-110-116-122-128-134-140-146 cm Pages 4, 12-15

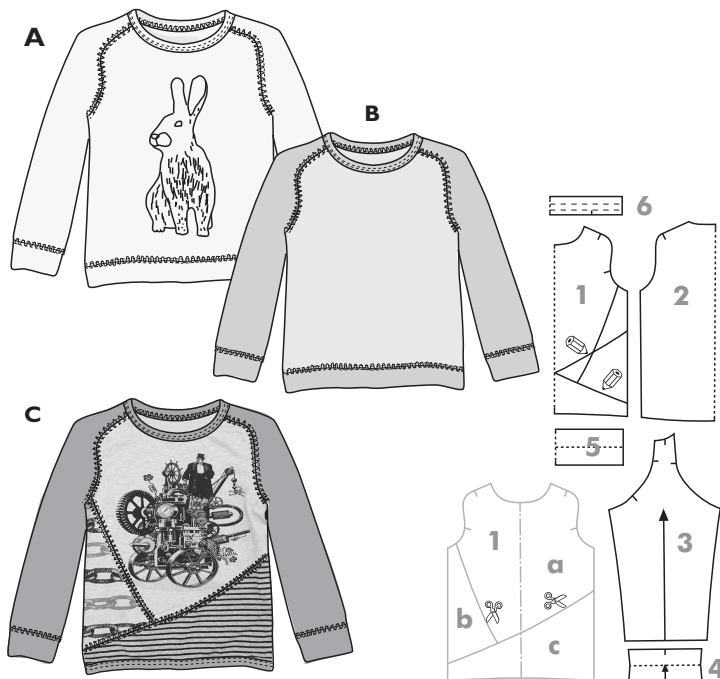

### CUTTING

**Design A:** Cut garment pieces from single jersey as indicated on list of pattern pieces, placing center-front and center-back edges of pattern pieces on fabric fold and adding 7 mm seam allowances to all other edges except neckline.

**Design B:** Cut front and back from pale-blue and other garment pieces from medium-blue single jersey as indicated on list of pattern pieces, placing center-front and center-back edges of pattern pieces on fabric fold and adding 7 mm seam allowances to all other edges except neckline.

**Design C:** Trace pattern for front so that it represents the whole of garment's front, observing markings on small-scale pattern. Cut up pattern for front into three separate pattern pieces along marked seamlines. Cut garment pieces as follows: front panel (a) from steampunk-patterned, lower front panel (c) from striped, side front panel (b) and back panel from chain-patterned, and sleeves and sleeve cuffs from black single jersey as indicated on list of pattern pieces, placing center-front and center-back edges of pattern pieces on fabric fold and adding 7 mm seam allowances to all other edges except neckline \*.\*.

Cut 4.5 cm wide binding strips from ribbing for finishing neckline and bottom-hem edge. If you use a binder attachment on your coverstitch machine to attach the bindings, cut the binding strips in the width that fits the binder.

### SEWING

**Construction techniques:** Stitch raglan seams on all designs and panel seams on the front of design C as follows: Place garment pieces right sides together and stitch seam with straight stitch. Trim seam allowances to 5 mm and press seam open. Topstitch seam from right side of garment with coverstitch. Stitch sleeve underarm seams and side seams with serger or with overedge stretch stitch on regular sewing machine. Stitch coverstitching with 5-thread coverstitch or use suitable decorative stitch on regular sewing machine (e.g. honeycomb stitch). **Design C:** See general instructions for finishing edges with bindings on p. 44.

**Bunny motif, design A:** Lay the front panel on a flat surface and pull it taut. Draw a bunny (or some other motif) on the panel with a fabric marker. If you wish, you can baste the outlines of the motif on the front panel before drawing.

**Sleeve cuffs:** Stitch sleeve cuffs to bottom

### PATTERN PIECES

PATTERN PIECES	cut
1 front A+B	1
1 front C	1
1 front panel a	1
1 side front panel b	1
1 lower front panel c	1
2 back	1
3 sleeve	2
4 sleeve cuff	2
5 hem band A+B	2
6 neckline binding A+B	1

sizes 92-122

PATTERN SHEET **B** blue

sizes 128-146

PATTERN SHEET **D** green

edges of sleeves as follows: Pin and stitch one edge of cuff to bottom edge of sleeve right sides together, stretching cuff slightly as you sew. Press seam open, fold cuff in half wrong sides together and pin its free edge to sleeve-edge seam. Stitch cuff in place from right side of sleeve with 5-thread coverstitch, placing stitching in the middle of sleeve-edge seamline.

**Joining, designs A and B:** Pin sleeves to front and back panels right sides together and stitch and topstitch raglan seams as instructed above in Construction techniques. Stitch sleeve underarm seams and side seams. Fold underarm seam allowances to one side at bottom edges of sleeves and stitch them flat for a couple of centimeters. Stitch side seams of hem bands right sides together. Stitch band to garment's bottom-hem edge in the same way as cuffs to sleeves.

**Neckline, designs A and B:** Stitch ends of neckline binding together to form circle and mark binding into quarters. Also, mark neckline into quarters (start measuring at left raglan seam on back and, when applying neckline binding, align seam on binding with this seam). Pin and stitch neckline binding to neckline right sides together, stretching it slightly as you sew. Wrap binding over neckline edge to

wrong side, pin its free edge to neckline and stitch close to binding seamline from right side of garment with 3-thread coverstitch or with twin needle on regular sewing machine, catching free edge of binding in stitching.

**Joining, design C:** Pin front panel and side front panel right sides together and stitch and topstitch panel seam as instructed above in Construction techniques. Stitch lower front panel to front + side front panel in the same way. Pin sleeves to front and back panels right sides together and stitch and topstitch both raglan seams on front and right raglan seam on back as instructed in Construction techniques. Finish neckline with ribbed binding. Stitch and topstitch left raglan seam on back. Stitch seam allowances flat along outer edge of neckline binding with short row of back-and-forth stitching.

Stitch right sleeve-underarm seam and side seam. Finish bottom-hem edge with binding. Stitch left sleeve-underarm seam and side seam. Fold seam allowances to one side and stitch them flat across bottom-hem binding as well as for a couple of centimeters at bottom edges of sleeves.

## 16. Chameleon pants from corduroy, canvas or satin 92-98-104-110-116-122-128 cm Pages 4-5,12-15, 60-61

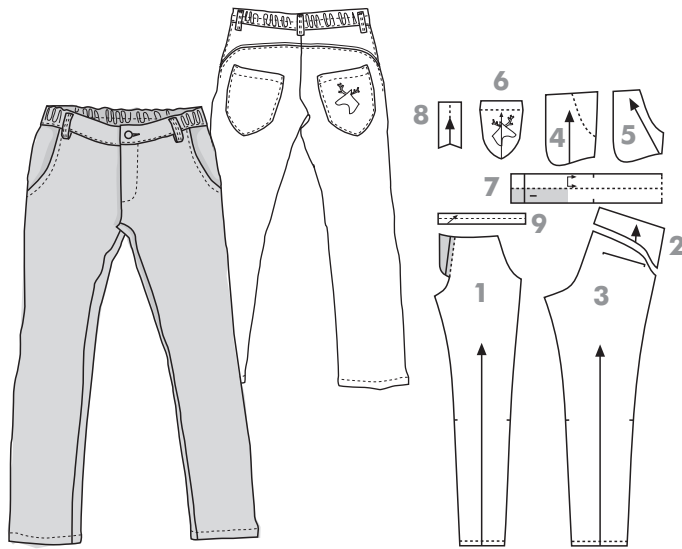

### PATTERN PIECES cut

1 pants front	2
2 back yoke	2
3 pants back	2
4 pocket piece	2
5 pocket facing	2
6 back pocket A+B	2
7 waistband	1
8 fly shield	1
9 piping trim*	2
☞ reindeer motif B	

### PATTERN SHEET C black

### MATERIALS

- 60-65-70-75-80-85-90 cm stretch corduroy (CO/EL), design A, or printed stretch canvas (CO/EL), design B, or stretch satin (CO/PES/EL), design C, stretch/recovery 8%
- 25 cm printed (A) or solid-color (B) cotton fabric for pocket facings and piping trims on back yokes
- piece of interfacing, Vlieseline® H 180
- 36-37-38-39-40-41-42 cm elastic, width 25 mm
- zipper, length 6-6-7-7-8-8-9 cm
- 1 snap fastener or button, ø 15 mm
- topstitching thread, Epic no. 80 (- piece of double-sided fusible web, Vlieseline® Vliesofix)

### CUTTING

**Designs A and B:** Cut pocket facings and piping trims from cotton fabric and other garment pieces from corduroy or canvas as indicated on list of pattern pieces, placing center-back edge of pattern piece for waistband on fabric fold and adding 10 mm seam allowances to other edges. \*Pattern piece for piping trim includes seam allowances.

**Design C:** Cut all garment pieces from satin as indicated on list of pattern pieces, placing center-back edge of pattern piece for waistband on fabric fold and adding 10 mm seam allowances to other edges. \*Pattern piece for piping trim includes seam allowances.

**All designs:** Cut 3 cm x 33 cm strip from fashion fabric for belt loops.

### SEWING

**Construction techniques:** Stitch seams with straight stitch and finish them with serger or zigzag stitch. Topstitch edges of pocket openings on pants fronts using presser-foot edge as guide and topstitch seams and other edges close to seamline or edge; use contrast-color topstitching

thread on designs A and B and matching topstitching thread on design C.

**Stabilizing:** Fuse interfacing to waistband and on design C (satin pants) also to fly facing (see areas shaded in grey on small-scale patterns).

**Appliqué, design B:** Trace reindeer motif from pattern sheet on paper backing of double-sided fusible web and fuse web to wrong side of piece of solid-color cotton fabric. Cut appliqué shape out along its outlines, remove paper backing and iron shape onto one of the back pockets. Stitch shape in place close to edge with straight stitch.

**Front-hip pockets:** Pin and stitch pocket facings to edges of pocket openings on pants fronts, right sides together. Clip seam allowances along curves. Understitch seam allowances to pocket facings close to seamline. Fold pocket facings to wrong side of pants fronts and topstitch edges of pocket openings. Pin pocket pieces to pocket facings right sides together and stitch bottom of each pocket. Pin and machine-baste pockets to waist and side seam allowances of pants fronts.

**Back pockets, designs A and B:** Fold,

press and stitch hems at opening edges of pockets as marked on pattern. Turn and press seam allowances at other pocket edges to wrong side, pin pockets to pants backs as marked on pattern and topstitch in place.

**Joining:** Fold piping trims in half lengthwise, wrong sides together. Machine-baste trims to top edges of pants backs, placing their open edges along outer edges of seam allowances on pants backs and stitching 3 mm away from folded edges of trims. Pin back yokes to pants backs right sides together and stitch them in place along stitching lines that attach piping trims. Fold seam allowances toward pants backs and topstitch seams.

Stitch front crotch seam from leg inseam edge to notch for zipper placket. Apply zipper to placket, following illustrated instructions for fly-front zipper on p. 45. Pin pants fronts and backs right sides together and stitch side seams. Fold seam allowances toward pants backs and topstitch side seams from waist edge to bottom edge of front-hip pocket. Stitch back crotch seam. Topstitch front and back crotch seams. Pin and stitch leg inseams. Fold up, press and stitch hems at bottom

edges of legs.

**Belt loops:** Finish one raw long edge of belt loop strip. Fold strip in three lengthwise and stitch two parallel rows of topstitching in the middle of strip. Cut strip into five equal-length pieces. Pin and stitch one end of each belt loop to pants waist as shown in design sketch, right sides together.

**Waistline:** Machine-baste ends of elastic to waistband as marked on pattern. Pin and stitch right side of inner half of waistband to wrong side of pants waist. Fold waistband right sides together and stitch its ends. Trim corners and turn ends of waistband right side out. Turn waistband right way up, turn seam allowance at its free outer edge under and stitch edge to right side of pants waist. Sew another row of stitching along elasticated portion of waistband, stitching through all layers in the middle of elastic and stretching elastic as you sew. Stitch free ends of belt loops to top edge of waistband. Attach snap fastener to waistband, or stitch buttonhole and sew button on it, as marked on pattern.

## 17. Odd Zippers baseball jacket 92-98-104-110-116-122-128 cm

Pages 4, 15



### MATERIALS

- 50-50-50-55-55-60-60 cm pale-grey and 40-40-45-45-45-50-50 cm dark-grey mélange sweatshirt knit (CO/EL), stretch/recovery 30%
- 25 cm ribbing (CO/EL), width 90 cm
- piece of lightweight cotton fabric

- for outer pocket pieces
- piece of interfacing, Vlieseline® G 785
- 3 metal zippers: 1 open-end zipper, length 25-27-29-31-33-35-37 cm, for front and 2 regular zippers, length 12 cm, for pockets
- contrast-color topstitching thread, Epic no. 80



## CUTTING

Cut sleeve cuffs, hem band and collar from ribbing, outer pocket pieces from cotton fabric, inner pocket pieces, elbow patches, front panels and back panel from pale-grey sweatshirt knit and sleeves from dark-grey sweatshirt knit as indicated on list of pattern pieces, placing center-back edges of pattern pieces on fabric fold and adding 10 mm seam allowances to other edges.

## SEWING

**Construction techniques:** Stitch seams with straight stitch and finish them with serger or zigzag stitch unless otherwise instructed. Topstitch seams and edges with contrast-color topstitching thread using presser-foot edge as guide unless otherwise instructed. Stitch coverstitching with 5-thread coverstitch or use suitable decorative stitch on regular sewing machine (e.g. honeycomb stitch).

**Stabilizing:** Fuse interfacing to wrong side of pocket opening areas on front panels and fuse also narrow strips of interfacing to front-edge seam allowances on front panels (see areas shaded in grey on small-scale patterns).

**Pockets:** Place outer pocket piece on front panel right sides together and stitch around pocket opening, observing pattern markings. Slash pocket opening between stitching lines and clip diagonally to corners. Fold pocket piece to wrong side

and press edges of pocket opening. Turn ends of zipper tapes to wrong side, pin zipper over pocket opening and stitch it in place close to its outer edges. Sew another two rows of stitching along zipper, placing them on each side of zipper teeth. Pin and stitch inner pocket piece to outer pocket piece right sides together. Sew rows of back-and-forth stitching through all layers across each end of pocket opening.

**Sleeves:** Finish bottom edges of sleeves following instructions for design 15. Pin elbow patches to sleeves as marked on pattern and stitch them in place with 5-thread coverstitch; do not turn edges of patches under.

**Joining:** Pin front and back panels right sides together and stitch shoulder seams with straight stitch. Trim seam allowances to 5 mm and press seams open. Topstitch shoulder seams from right side with 5-thread coverstitch. Stitch sleeves to armholes right sides together. Fold seam allowances toward body of garment and topstitch seams. Stitch sleeve underarm seams and side seams. Fold underarm seam allowances to one side at bottom edges of sleeves and stitch them flat for a couple of centimeters.

**Collar:** Fold collar in half wrong sides together and stitch it to neckline right sides together, aligning its front tips with front-edge seamlines on front panels. Fold neckline seam allowances toward body

of garment and topstitch neckline seam.

**Hemline:** Finish raw horizontal edges of front-corner hem allowances on front panels. Fold hem band in half wrong sides together and stitch its long edge to garment's bottom-hem edge right sides together; before stitching, clip diagonally through seam allowance at inward corner on each front panel and lay hem band so that seamline across each of its ends is aligned with tip of clip. Fold front-corners of front panels onto ends of hem band right sides together, fold front-corner hem allowances onto underside of hem band and stitch ends of hem band to front panels. Turn corners right side out. Fold seam allowances of bottom-hem seam toward front and back panels and topstitch bottom-hem seam and vertical seams at ends of hem band with continuous row of stitching.

**Zipper:** Open zipper. Stitch zipper halves to front panels right sides together, aligning bottom end of zipper with folded bottom-hem edge of front panel. Wrap top ends of zipper tapes over neckline edge to wrong side, pin zipper tapes right way up and stitch their outer edges to front panels.

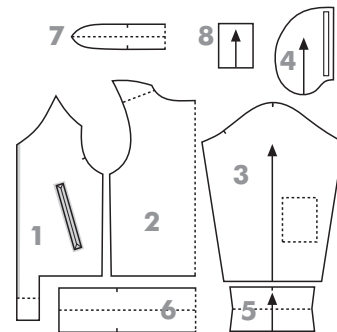

### PATTERN PIECES

PATTERN PIECES	cut
1 front	2
2 back	1
3 sleeve	2
4 pocket piece	2+2
5 sleeve cuff	2
6 hem band	1
7 collar	1
8 elbow patch	2

### PATTERN SHEET C green

## 18. Wayne shirt

92-98-104-110-116-122-128 cm

Pages 60-61



### MATERIALS

- 75-80-85-90-90-95-100 cm printed organic-cotton poplin (CO)
- 35...50 cm interfacing, Vlieseline® H 180
- 10...12 open-ring snap fasteners, ø 10 mm

## CUTTING

Trace pattern piece for right front panel from pattern for left front panel, observing markings on small-scale pattern. Cut garment pieces from fabric as indicated on list of pattern pieces, placing center-back edges of pattern pieces on fabric fold and adding 10 mm seam allowances to other edges. Cut also two 3 cm x 16 cm strips for cuff placket bindings.

## SEWING

**Construction techniques:** Stitch seams with straight stitch and finish them with serger or zigzag stitch. Sew topstitching

close to edge or seamline unless otherwise instructed.

**Stabilizing:** Fuse interfacing to front facings, outer collar stand, upper collar, outer halves of sleeve cuffs and outer pocket flap. See areas shaded in grey on small-scale patterns.

**Pocket:** Fold, press and stitch hem at opening edge of pocket. Turn and press seam allowances at other pocket edges to wrong side, and pin and stitch pocket to left front panel as marked on pattern. Pin pocket flap pieces right sides together and stitch their curved outer edges. Trim corner of flap diagonally, trim seam allow-

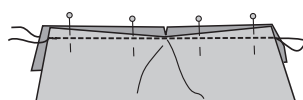

### PATTERN PIECES

PATTERN PIECES	cut
1 shoulder yoke	1
2 left front panel	1
2 right front panel	1
3 front facing	1+1
4 back	1
5 sleeve	2
6 sleeve cuff	2
7 pocket	1
8 pocket flap	2
9 collar	2
10 collar stand	2

### PATTERN SHEET C red

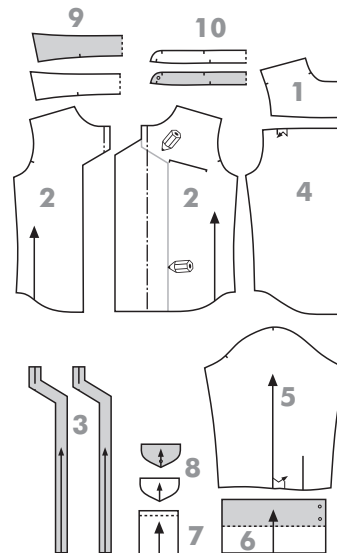

ances slightly and turn flap right side out. Press pocket flap flat and topstitch its edges using presser-foot edge as guide. Pin and stitch flap above pocket, with outside of flap facing right side of front panel. Fold flap right way up and topstitch attachment seam, concealing seam allowances under flap.

**Cuff plackets:** Slash bottom edges of sleeves for cuff plackets as marked on pattern. Pin and stitch placket bindings to placket edges, with right side of binding facing wrong side of sleeve; leave even 7 mm seam allowance all along edge of binding while placing stitching 7 mm away

from placket edges at bottom edge of sleeve and 1 mm away from placket edges at top end of placket (see illustration). Fold binding in half, turn seam allowance at its free edge under and stitch turned-under edge to right side of placket close to edge. Stitch small dart at top end of each placket. Leave placket edge closest to underarm seam straight and fold the other placket edge to wrong side of sleeve. Fold pleats at bottom edges of sleeves as marked on pattern and machine-baste them in position. >>>



**Joining:** Fold pleats on back panel and machine-baste them in position. Pin and stitch front and back panels to shoulder yoke right sides together. Fold seam allowances toward yoke and topstitch seams. Pin and stitch sleeves to armholes, fold seam allowances toward body of garment and topstitch seams using presser-foot edge as guide. Stitch sleeve underarm seams and side seams.

**Front facings:** Pin and stitch front facings to front panels right sides together. Trim seam allowances around outward corners

and clip to stitching at inward corners. First press seams open, then fold front facings to wrong side of front panels and press front edges. Turn seam allowances at outer edges of front facings to wrong side, pin edges to front panels and stitch them in place close to edge. Stitch narrow hem at garment's bottom edge.

**Collar:** Construct collar with a stand following illustrated instructions on page 45.

**Sleeve cuffs:** Turn and press seam allowance at attachment edge of outer half (interfaced half) of sleeve cuff to wrong side. Fold cuff in half right sides together and stitch its side edges. Turn cuff right side out and press it flat. Pin and stitch right side of inner cuff half to wrong side of bottom edge of sleeve. Turn cuff right way out. Pin edge of outer cuff half to sleeve edge and stitch it to sleeve close to edge. Topstitch around cuff.

**Finishing:** Attach snap fasteners to pocket and sleeve cuffs as marked on pattern.

Attach socket halves of snap fasteners to left front panel and stud halves to right front panel as follows: top snap to collar stand as marked on pattern, the next two snaps to inward and outward corners on front panels and the rest at regular intervals below these.

## 19. Pappa's slipover vest

92-98-104-110-116-122-128 cm

Page 60

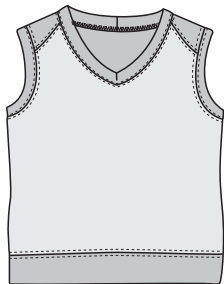

### MATERIALS

- 40-45-45-50-50-55-55 cm dark-grey and 40-40-45-45-50-50-50 cm pale-grey merino wool single jersey (WV), width 145 cm, weight 256 g/m2

### PATTERN PIECES

	cut
1 front	1
2 back	1
9 neckline binding	1
10 armhole binding	2
11 hem band	2

### PATTERN SHEET C green

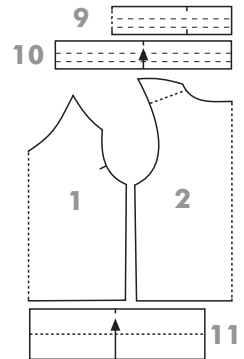

### CUTTING

Cut front from pale-grey and other garment pieces from dark-grey knit as indicated on list of pattern pieces, placing center-front and center-back edges of pattern pieces on fabric fold and adding 7 mm seam allowances to other edges.

### SEWING

**Construction techniques:** Stitch side seams of garment with serger or with overedge stretch stitch on regular sewing machine. Stitch topstitching on neckline

and armhole bindings, hem band and shoulder seams with 3-thread coverstitch (2 needles) or 4-thread coverstitch (3 needles), or with twin needle on regular sewing machine.

**Shoulder seams:** Pin front and back right sides together and stitch shoulder seams with straight stitch. Steam seams open and topstitch them from right side, placing stitching over seamline.

**Neckline binding:** Stitch ends of neckline binding together to form circle. Mark both binding and neckline into quarters

(start measuring and marking at center-back point at neckline and, when applying neckline binding, place seam on binding at this point). Pin binding to neckline right sides together, aligning quarter marks, and stitch it in place with straight stitch. Steam neckline seam open, fold binding in half wrong sides together and pin its free edge to wrong side of neckline seam. Topstitch neckline seam from right side, placing stitching over seamline so that one outer line of topstitching runs along neckline binding and the other on body of garment. Stitch small dart on neckline

binding at center-front corner of neckline.

**Joining:** Mark shoulder seam point on each armhole binding, pin bindings to armholes and stitch them in place in the same way as neckline binding. Stitch side seams. Fold side seam allowances to one side and stitch them flat across armhole bindings. Pin hem bands right sides together and stitch side seams. Stitch hem band to garment's bottom-hem edge in the same way as neckline binding.

## 20. Keijuhelma skirt

110-116-122-128-134-140-146 cm

Pages 4, 8-9, 62

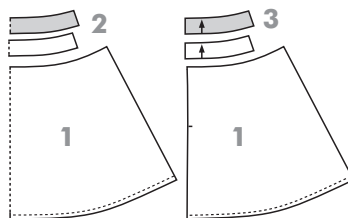
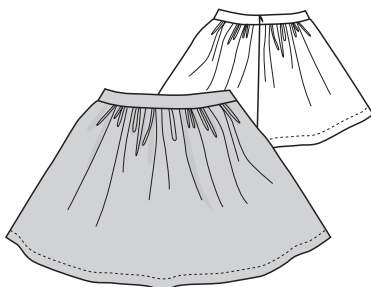

### CUTTING

Cut garment pieces from fabric as indicated on list of pattern pieces, placing center-front edges of pattern pieces on fabric fold and adding 10 mm seam allowances to other edges.

### SEWING

**Construction techniques:** Stitch seams with straight stitch and finish them with serger or zigzag stitch. Stitch zipper using invisible zipper foot.

**Stabilizing:** Fuse interfacing to outer (or if necessary, to all) waistband pieces.

**Joining:** Pin skirt front and backs right sides together and stitch side seams. Sew gathering stitches along waist edge of skirt and gather skirt front and back to match corresponding waistband pieces.

**Waistline and zipper:** Pin outer front and back waistband pieces right sides together and stitch side seams. Press seams open. Stitch side seams of waistband facing and press seams open. Finish raw bottom edge of waistband facing. Pin outer waistband and waistband facing right sides together and stitch their top edges. Clip seam allowances along curves and understitch them to waistband facing close to seamline.

### PATTERN PIECES

	cut
1 skirt front	1
1 skirt back	2
2 front waistband	1+1
3 back waistband	2+2

### PATTERN SHEET C orange

### MATERIALS

- 50-55-55-60-65-65 cm lightweight linen fabric (LI) or taffeta (PA/PES), width 145 cm  
- invisible zipper, length 15 cm  
- 10 cm interfacing, Vlieseline® H 180  
- iron-on hemming tape for taffeta skirt

Pin outer waistband to skirt right sides together and stitch waist seam. Finish raw center-back edges. Open zipper. Stitch zipper to center-back edges right sides together, aligning top end of zipper coil with top edge of waistband. Stitch center-back seam from bottom of zipper placket to bottom hem and press seam open.

Fold outer waistband and waistband facing right sides together on each side of zipper placket and stitch their center-back edges together, with zipper in between. Turn center-back ends of waistband right side out. Pin bottom edge of waistband facing to waist seam carefully and stitch-in-the-ditch along waist seamline from right side

of garment. Remove gathering stitches.

**Finishing:** Finish raw bottom-hem edge. Sew row of ease-stitching along outer edge of bottom-hem seam allowance and pull up bobbin thread to ease out the fullness of hem. Fold up and press bottom hem as marked on pattern. Linen skirt: Stitch hem with straight stitch. Taffeta skirt: Attach hem using iron-on hemming tape; cut clips on edge of tape to make it curve along hemline.

## 21. Tiny Pussy Bow blouse

110-116-122-128-134-140-146 cm

Page 4, 8-9



### MATERIALS

- 60-75-80-85-90-95-100 cm lightweight printed cotton batiste (CO)
- 5 cm interfacing, Vlieseline® G 785
- 5...6 buttons, ø 12 mm
- 38-39-40-41-42-43-44 cm elastic, width 8 mm

### CUTTING

Cut garment pieces from fabric as indicated on list of pattern pieces, placing center-back edges of pattern pieces on fabric fold and adding 10 mm seam allowances to other edges.

### SEWING

**Construction techniques:** Stitch seams with straight stitch and finish them with serger or zigzag stitch.

**Stabilizing:** Fuse interfacing to front facings and collar (see areas shaded in grey on small-scale patterns).

**Joining:** Sew gathering stitches along top edges of front and back panels as marked

on pattern and gather edges to fit shoulder yoke. Stitch shoulder yoke to front and back panels, fold seam allowances toward yoke and topstitch seams close to seamline. Stitch sleeves to armholes. Stitch sleeve underarm seams and side seams.

Fold front facings to wrong side of front panels as marked on pattern and press. Fold each front facing onto right side of front panel, turn seam allowance at its outer edge in position and stitch neckline edges together from folded front edge to pattern marking for collar. Clip to stitching at pattern marking for collar and turn front neckline corner right side out. Turn seam allowances at outer edges of

### PATTERN PIECES

	cut
1 shoulder yoke	1
2 front	2
3 back	1
4 sleeve	2
5 collar	1

### PATTERN SHEET C blue

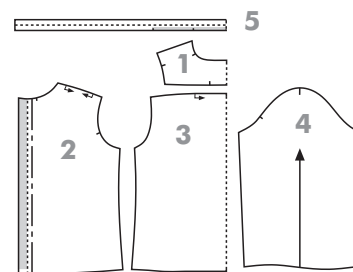

front facings to wrong side, pin facings to front panels and stitch them in place close to edge. Stitch narrow hem at garment's bottom edge.

**Collar:** Fold collar in half right sides together and stitch ends as well as long edges of collar ties as far as pattern markings. Finger-press seams open carefully and turn collar right side out. Press fold on collar as marked on pattern and, at the same time, press collar ties gently. Pin and stitch right side of non-interfaced half of collar to wrong side of neckline. Turn seam allowance at bottom edge of outer collar half under; pin turned-under edge to neckline and stitch in place close to edge.

**Bottom edges of sleeves:** Cut elastic into two equal-length pieces and stitch ends of each piece together to form circles. Finish raw bottom edges of sleeves. Machine-baste circles of elastic to seam allowances at bottom edges of sleeves, stretching them slightly as you sew. Turn sleeve-edge seam allowances with elastic to wrong side and stitch sleeve edges along edge of elastic.

**Finishing:** Stitch buttonholes and sew buttons on front edges, placing top buttonhole and button 2 cm below neckline seam and the rest at regular 6...7 cm intervals.

## 22. Keeping Cosy

furry short-sleeve jacket

110-116-122-128-134-140-146 cm Page 9



### MATERIALS

- 45-45-50-50-55-55-60 cm soft organic-cotton sweatshirt knit (CO)
- 40-40-45-45-50-50-55 cm organic-cotton faux fur knit (CO), width 110 cm
- 65...95 cm fusible stay tape, width 12 mm, Vlieseline® Formband
- open-end zipper, length 30-32-34-36-39-42-44 cm
- 53-54-55-56-57-58-59 cm elastic, width 10 mm

### CUTTING

Cut front panels from faux fur and other garment pieces from sweatshirt knit as indicated on list of pattern pieces, placing center-back edges of pattern pieces on fabric fold and adding 10 mm seam allowances to all other edges except neckline. \*Pattern piece for neckline binding includes seam allowances.

### SEWING

**Construction techniques:** Stitch seams with straight stitch and finish them with serger or zigzag stitch. Stitch coverstitching with 5-thread coverstitch or use suitable decorative stitch on regular sewing machine (e.g. honeycomb stitch) unless oth-

erwise instructed.

**Stabilizing:** Fuse pieces of stay tape to center-front edges of front panels and hem band (see edges shaded in grey on small-scale patterns).

**Joining:** Pin front and back panels right sides together and stitch shoulder seams with straight stitch. Trim seam allowances slightly and press seams open. Topstitch shoulder seams from right side with 5-thread coverstitch, placing stitching over seamline. Sew gathering stitches along sleeve caps as marked on pattern and gather sleeves to fit armholes. Stitch sleeves to armholes right sides together. Stitch sleeve underarm seams and side seams.

### PATTERN PIECES

	cut
1 front	2
2 back	1
3 sleeve	2
4 neckline binding*	1
5 hem band	1

### PATTERN SHEET D lilac

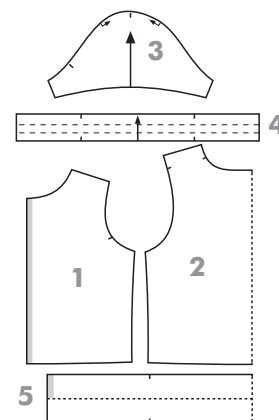

**Bottom edges of sleeves:** Finish bottom edges of sleeves following instructions for design 21.

**Neckline:** Pin and stitch one edge of neckline binding to neckline right sides together. Wrap binding over neckline edge to wrong side, pin its free edge to neckline and stitch close to binding seamline from right side of garment with 3-thread coverstitch or with twin needle on regular sewing machine, catching free edge of binding in stitching.

**Hemline:** Pin and stitch one edge of hem band to garment's bottom-hem edge right sides together, stretching hem band slightly as you sew. Press seam open, fold hem band in half wrong sides together

and pin its free edge to bottom-hem seam. Stitch hem band in place from right side of garment with 5-thread coverstitch, placing stitching in the middle of bottom-hem seamline.

**Zipper:** Open zipper. Pin and stitch zipper tapes to garment's front edges right sides together, aligning top end of zipper teeth with top edge of neckline binding and bottom end with bottom edge of hem band (shorten zipper if necessary). Wrap ends of zipper tapes over neckline binding to wrong side, turn zipper tapes right way up and stitch their outer edges to front panels.

## 23. Fox Forest jersey dress

128-134-140-146-152-158-164-170 cm

Pages 4, 10-11



### MATERIALS

- 70-75-75-80-85-90-90-95 cm printed organic-cotton single jersey (CO/EL), stretch/recovery 30%  
 - 65-70-80-85-85-90-90-95 cm mélange cotton/viscose blend single jersey (CO/CV/EL), stretch/recovery 30%  
 - 25 cm clear elastic tape, width 5 mm, Framilon®

### CUTTING

Cut front panel from printed single jersey and other garment pieces from mélange single jersey as indicated on list of pattern pieces, placing center-front and center-back edges of pattern pieces on fabric fold and adding 7 mm seam allowances to all other edges except neckline. \*Pattern piece for neckline binding includes seam allowances.

### SEWING

**Construction techniques:** Stitch seams with serger or with overedge stretch

stitch on regular sewing machine. Stitch hems with 3-thread coverstitch or with twin needle on regular sewing machine.

**Preparation:** Cut 11 cm piece of clear elastic tape for gathering front neckline and 14 cm piece for gathering top edge of back panel. Machine-baste clear elastic tapes to front neckline and top edge of back panel, placing them on right side of seam allowances between pattern markings and stretching them as you sew to gather edges evenly. On finished garment, clear elastic tapes will be concealed between seam allowances.

### PATTERN PIECES

PATTERN PIECES	cut
1 shoulder yoke	1
2 front	1
3 back	1
4 sleeve	2
5 neckline binding*	1

### PATTERN SHEET D red

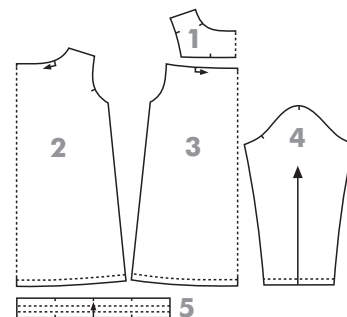

**Joining:** Pin shoulder yoke to front and back panels right sides together and stitch yoke seams. Fold up, press and stitch hems at bottom edges of sleeves as marked on pattern. Stitch sleeves to armholes. Stitch sleeve underarm seams and side seams. Fold underarm seam allowances to one side and stitch them flat across sleeve-edge hems. Fold up, press and stitch bottom hem as marked on pattern.

**Neckline:** Stitch ends of neckline binding together to form circle and mark binding into quarters. Also, mark neckline into quarters (start measuring and marking

at center-back point at neckline and, when applying neckline binding, align seam on binding with this point). Pin and stitch neckline binding to neckline right sides together, stretching it slightly as you sew. Wrap binding over neckline edge to wrong side, pin its free edge to neckline and stitch close to binding seamline from right side of garment with 3-thread coverstitch or with twin needle on regular sewing machine, catching free edge of binding in stitching.

## 24. Easy Wear hooded cardigan

128-134-140-146-152-158-164-170 cm

Page 13

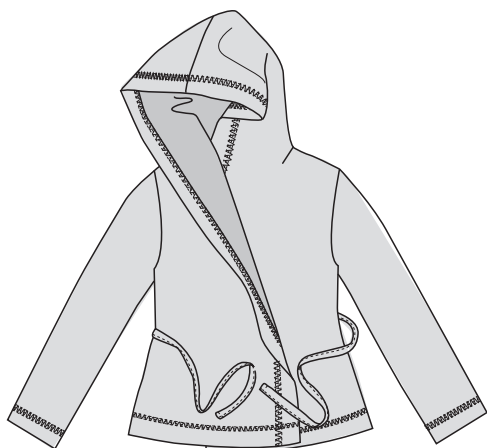

### MATERIALS

- 115-120-125-125-130-135-140-150 cm two-tone viscose single jersey (CV/EL), width 130 cm  
 - 50...60 cm clear elastic tape, width 5 mm, Framilon®

### PATTERN PIECES

PATTERN PIECES	cut
1+1A front	2
2 back	1
3 sleeve	2

### PATTERN SHEET D blue

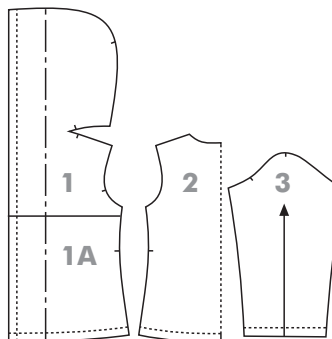

### CUTTING

Join pattern pieces 1+1A before cutting. Cut garment pieces from single jersey as indicated on list of pattern pieces, placing center-back edge of pattern on fabric fold and adding 7 mm seam allowances to other edges. Cut also 4 cm x 120 cm strip for belt and 2 cm x 10 cm strip for belt loops.

### SEWING

**Construction techniques:** Stitch seams with serger or with overedge stretch stitch on regular sewing machine. Stitch hems with 5-thread coverstitch or with suitable decorative stitch on regular sew-

ing machine (e.g. honeycomb stitch).

**Stabilizing:** Cut pieces of clear elastic tape for back neckline and shoulder edges on back panel (measure required lengths of tape on pattern and add seam allowances). Machine-baste tapes to right side of neckline and shoulder seam allowances on back panel (on finished garment, tapes will be concealed between seam allowances).

**Belt loops:** Fold belt loop strip in half lengthwise, wrong sides together, and stitch its long edges together with serger rolled hem or with narrow, short zigzag (finished width of strip = approx. 5 mm). Cut two 4 cm long pieces from strip, fold

them in half to form belt loops and machine-baste loops to side seam allowances on front panels as marked on pattern.

**Joining:** Pin hood sections of front panels right sides together and stitch top/back seam of hood. Pin front and back panels right sides together and stitch shoulder seams, aligning back neckline with pattern markings on shoulder edges of front panels. Pin bottom edge of hood to front and back neckline and stitch neckline seam. Secure thread ends at the beginning and end of stitching carefully.

Fold up, press and stitch hems at bottom edges of sleeves as marked on pattern. Stitch sleeves to armholes. Stitch sleeve

underarm seams and side seams. Fold underarm seam allowances to one side and stitch them flat across sleeve-edge hems. Fold up, press and stitch bottom hem as marked on pattern. Fold, press and stitch hem at face edge of hood and along front edges of front panels as marked on pattern. Secure thread ends at the beginning and end of stitching carefully.

**Belt:** Fold belt in half right sides together and stitch long edges together with serger. Turn belt right side out and stitch narrow hems at its ends. Thread belt through belt loops.

## 25. Wendy dress

134-140-146-152-158-164-170 cm

Pages 63-64

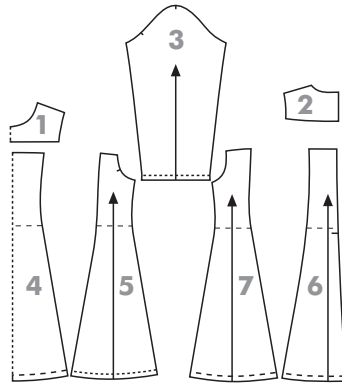

### PATTERN PIECES cut

1 front yoke	1
2 back yoke	2
3 sleeve	2
4 front	1
5 side front	2
6 back	2
7 side back	2

### PATTERN SHEET D black

### MATERIALS

- 60-60-60-65-65-70-70 cm firm interlock knit (techno jersey) (CV/PA/EL), stretch/recovery 20%
- 135-145-150-160-165-170-180 cm gold-coated linen-blend fabric (LI/CV/PES/PU), width 125 cm, stretch/recovery 10%
- 25 cm clear elastic tape, width 5 mm, Framilon®
- invisible zipper, length 40 cm
- iron-on hemming tape

### CUTTING

Cut yokes and sleeves from interlock knit and other garment pieces from linen-blend fabric as indicated on list of pattern pieces, placing center-front edges of pattern pieces on fabric fold and adding 10 mm seam allowances to other edges. Cut also 3 cm wide facing strip from interlock knit for finishing neckline. Measure required length of facing on pattern pieces and add seam allowances.

### SEWING

**Construction techniques:** Stitch seams with straight stitch and finish them with serger or zigzag stitch.

**Stabilizing shoulder seams:** Stabilize

shoulder seams with clear elastic tape following instructions for design 31.

**Joining body of dress:** Pin and stitch side fronts to front panel right sides together. Press seam allowances gently toward front panel. Stitch side backs to back panels in the same way.

**Yokes and neckline:** Pin front and back yokes right sides together and stitch shoulder seams. Press seam allowances toward back yoke. Pin and stitch one edge of neckline facing to neckline right sides together. Trim neckline seam allowances and clip them along curves. Understitch neckline seam allowances to neckline facing close to seamline. Fold facing to wrong side of neckline, turn seam allowance at its free edge under and stitch

turned-under edge to neckline close to edge.

**Joining:** Pin and stitch yokes to dress front and backs right sides together. Press seam allowances toward yokes. Stitch sleeves to armholes. Stitch sleeve underarm seams and side seams. Fold up and press hems at bottom edges of sleeves and stitch them with 3-thread coverstitch or with twin needle on regular sewing machine.

**Zipper:** Finish raw center-back edges. Open zipper. Pin one zipper half to center-back edge right sides together, aligning top end of zipper coil with neckline edge, and stitch it in place using invisible zipper foot. Stitch the other zipper half to the other center-back edge in the same way.

Wrap ends of zipper tapes over neckline edge to wrong side, turn zipper right way up and secure ends of zipper tapes to neckline with short rows of back-and-forth stitching. Stitch center-back seam from bottom of zipper placket to bottom hem.

**Finishing:** Finish raw bottom-hem edge. Sew row of ease-stitching along outer edge of bottom-hem seam allowance and pull up bobbin thread to ease out the fullness of hem. Fold up and press bottom hem as marked on pattern. Attach hem using iron-on hemming tape; cut clips on edge of tape to make it curve along hemline.

## 26. Stars and Stripes hoodie

128-134-140-146-152-158-164-170 cm

Pages 4, 6-7

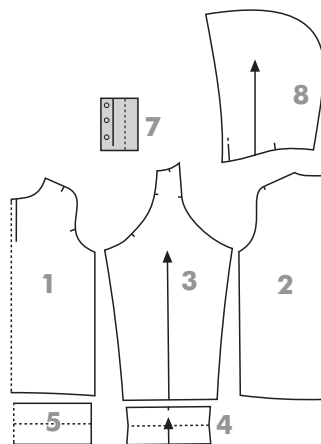

### PATTERN PIECES cut

1 front	1
2 back	1
3 sleeve	2
4 sleeve cuff	2
5 hem band	2
7 placket piece	1
8 hood	2+2

### PATTERN SHEET D green

### MATERIALS

- 55-60-60-65-65-70-70-70 cm star-patterned and 60-65-65-70-70-75-75-80 cm yellow-striped organic-cotton single jersey (CO/EL), stretch/recovery 30%
- 45 cm mélange cotton/viscose blend single jersey (CO/CV/EL), stretch/recovery 30%
- piece of interfacing, Vlieseline® G 785
- 3 open-ring snap fasteners, ø 10 mm, Prym

### CUTTING

Cut front and back from star-patterned, outer hood panels from mélange and other garment pieces from striped single jersey as indicated on list of pattern pieces, placing center-front and center-back edges of pattern pieces on fabric fold and adding 7 mm seam allowances to all other edges except face edges of hood panels. Cut also 3.5 cm wide binding strip from mélange single jersey for finishing face edge of hood. If you use a binder attachment on your coverstitch machine to attach the binding, cut the

binding strip in the width that fits the binder.

### SEWING

**Construction techniques:** Stitch raglan seams as follows: Place garment pieces right sides together and stitch seam with straight stitch. Trim seam allowances to 5 mm and press seam open. Topstitch seam from right side of garment with 5-thread coverstitch or with suitable decorative stitch on regular sewing machine (e.g. honeycomb stitch).

Stitch front placket with straight stitch. Stitch sleeve underarm seams and side seams as well as neckline seam and top/back seams of hood sections with serger or with overedge stretch stitch on regular sewing machine. See general instructions for finishing edges with binding on p. 44.

**Front placket:** Fuse interfacing to placket piece. Construct placket on front panel following illustrated instructions on page 45.

**Sleeve cuffs:** Stitch sleeve cuffs to bottom edges of sleeves following instruc-

tions for design 15.

**Joining:** Pin sleeves to front and back panels right sides together and stitch and topstitch raglan seams as instructed above in Construction techniques. Stitch sleeve underarm seams and side seams. Fold underarm seam allowances to one side at bottom edges of sleeves and stitch them flat for a couple of centimeters. Stitch side seams of hem bands right sides together. Stitch band to garment's bottom-hem edge in the same way as cuffs to sleeves.

>>>



**Hood:** Pin hood panels right sides together in pairs and stitch top/back seams on both outer hood and hood lining. Press seams. Place outer hood and hood lining within one another, wrong sides together, and machine-baste their face

edges and bottom edges together. Finish face edge of hood with binding.

Pin hood to garment's neckline, with outer hood against right side of garment and aligning face edge of hood with outer

edges of front placket. Fold front placket facings onto right side of garment, over bottom-front corners of hood on hood lining side, and machine-baste their top edges to front neckline. Stitch neckline seam with serger.

**Finishing:** Attach snap fasteners to front placket as marked on pattern.

## 27. Urban Denim sweatshirt blazer

128-134-140-146-152-158-164-170 cm

Pages 4, 7

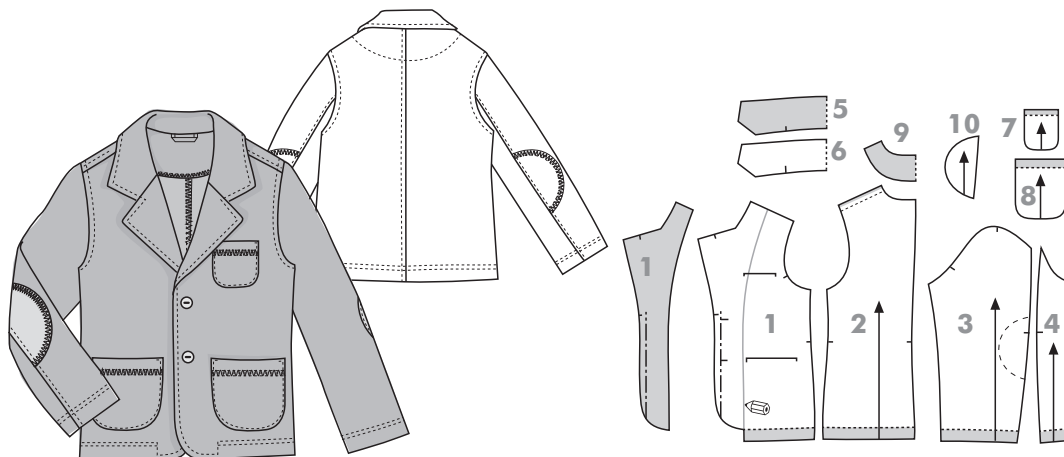

### PATTERN PIECES

PATTERN PIECES	cut
1 front	2
1 front facing	2
2 back	2
3 upper sleeve	2
4 under sleeve	2
5 upper collar	1
6 under collar	1
7 chest pocket	1
8 pocket	2
9 back facing	1
10 elbow patch	2

### PATTERN SHEET B orange

#### MATERIALS

- 100-110-115-125-125-135-140-145 cm denim-color and a piece of grey sweatshirt knit (CO/EL), stretch/recovery 25%, width 165 cm
- 50...70 cm interfacing, Vlieseline® H 180
- 2 metal buttons, ø 20 mm
- 10 cm piece of grosgrain ribbon, width 6 mm, for hanging loop
- contrast-color sewing thread and topstitching thread, Epic no. 80

#### CUTTING

Trace pattern piece for front facing from pattern for front. Cut elbow patches from grey and other garment pieces from denim-color sweatshirt knit as indicated on list of pattern pieces, placing center-back edges of pattern pieces for back facing and collars on fabric fold and adding 10 mm seam allowances to other edges.

#### SEWING

**Construction techniques:** Stitch seams

with straight stitch and finish them with serger or zigzag stitch. Sew topstitching using presser-foot edge as guide unless otherwise instructed. Stitch coverstitching with 5-thread coverstitch or use suitable decorative stitch on regular sewing machine (e.g. honeycomb stitch). Use contrast-color threads for topstitching and coverstitching.

**Stabilizing:** Fuse interfacing to upper collar, front and back facings, and hem allowances on sleeves, pockets and front and back panels, as well as to shoulder seam allowances on back panels. See areas shaded in grey on small-scale patterns.

**Pockets:** Fold and press hems at opening edges of pockets and stitch them with 5-thread coverstitch. Sew row of ease-stitching within seam allowance along curved edge of each pocket. Make cardboard template with pattern piece for pocket. Lay pocket on an ironing board wrong side up. Lay pocket template on wrong side of pocket. Holding template and pocket against ironing board, pull up bobbin thread of ease-stitching evenly to turn pocket seam allowances over edge of template to wrong side and press. Remove template. Pin pockets to front panels as marked on pattern and stitch them in place close to edge.

**Sleeves:** Pin elbow patches to upper sleeves as marked on pattern. Machine-baste straight edges of elbow patches to seam allowances on upper sleeves and stitch their curved edges to sleeves with 5-thread coverstitch. Pin upper sleeves and under sleeves right sides together and stitch back seam of each sleeve. Fold seam allowances toward upper sleeves and topstitch seams.

**Joining:** Pin back panels right sides together and stitch and topstitch center-back seam. Pin front and back panels right sides together and stitch shoulder seams. Fold seam allowances toward back panel and topstitch seams. Pin and stitch sleeves to armholes, fold seam allowances toward body of garment and topstitch seams. Stitch sleeve underarm seams and side seams.

**Collar and front facings:** Pin collar pieces right sides together and stitch their outer edges. Understitch seam allowances to under collar close to seamline. Fold collar pieces right sides together and stitch ends of collar. Turn collar right side out, press it and machine-baste its open edges together. Stitch collar to garment's neckline as marked on pattern. Fold grosgrain ribbon into hanging loop and machine-baste its ends to right side of neck-

line edge of collar, placing them on each side of center-back mark.

Pin front and back facings right sides together and stitch shoulder seams. Press seams open. Finish raw outer edge of facing section. Pin and stitch facing to garment's front edges and neckline right sides together, with collar in between. Trim seam allowances around outward corners and clip to stitching at inward corners. Turn facing section right side out and press it thoroughly. Fold up and press bottom hem and sleeve-edge hems. Topstitch front edges and outer edge of collar with continuous line of stitching, starting and ending stitching at outer edge of bottom hem allowance (see design sketch). Pin outer edge of back facing to back panel and stitch it in place close to edge.

**Finishing:** Stitch bottom hem and sleeve-edge hems with 3-thread coverstitch or with twin needle on regular sewing machine. Stitch buttonholes on left front panel and sew buttons on right front panel as marked on pattern.

## 28. Denim Look jersey jeans

128-134-140-146-152-158-164-170 cm

Pages 4, 6-7

#### CUTTING

Join pattern pieces 1+1A and 2+2A before cutting. Cut garment pieces from jersey as indicated on list of pattern pieces, adding 10 mm seam allowances to all edges.

#### SEWING

**Construction techniques:** Stitch seams

with straight stitch and finish them with serger or zigzag stitch. Decrease needle thread tension slightly and stretch garment pieces gently as you sew to produce durable seams. You can shrink seams back to their right length by steaming them. Topstitch side seams and hems at opening edges of back pockets with three parallel rows of stitching and topstitch the other seams and edges with two parallel rows

of stitching. Stitch bar-tacks with narrow, short zigzag, making them approx. 10 mm long.

**Front-hip pockets:** Construct front-hip pockets following instructions for design 16. Stitch edges of pocket openings to pocket pieces, starting from waist edge and stitching for approx. 8 cm along lines of topstitching. >>>

#### MATERIALS

- 85-90-95-100-105-105-110-115 cm firm, denim-look jersey knit with good recovery (CO/PES/EL), stretch/recovery 30%
- contrast-color topstitching thread, Epic no. 80
- 55...75 cm elastic, width 30 mm

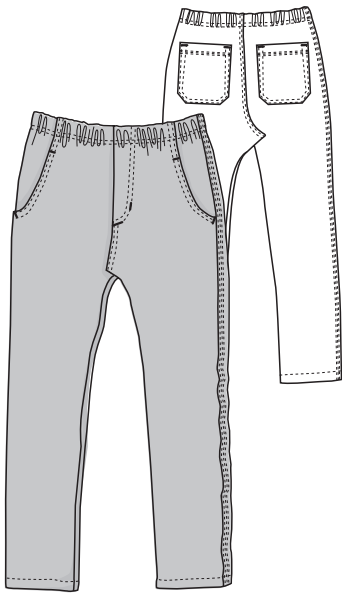

**Pants front:** Pin pants fronts right sides together and stitch center-front seam (note that along mock fly, stitching line runs along outer edges of mock fly extensions). Pin mock fly extensions to left pants front and stitch them in place with two parallel rows of topstitching. Topstitch center-front seam from bottom of mock fly to crotch. Stitch bar-tacks on mock fly and at edges of front-hip pocket openings as shown in design sketch.

**Pants back:** Fold, press and topstitch hems at opening edges of back pockets as marked on pattern. Turn and press seam allowances at other pocket edges to wrong side. Pin and topstitch pockets to pants backs as marked on pattern. Pin pants backs right sides together and stitch center-back seam. Fold seam allowances toward left pants back and topstitch seam.

**Joining:** Pin pants front and back right

sides together and stitch side seams. Fold seam allowances toward pants backs and topstitch side seams. Stitch leg inseams. Fold up, press and stitch hems at bottom edges of legs.

**Waistline:** Fold and press waist casing. Measure and cut piece of elastic to fit the child's waist and stitch its ends together to form circle. Mark elastic into quarters. Pin elastic to waist casing allowance, aligning quarter marks with center-front, center-back and side seams and placing top edge of elastic along casing foldline. Machine-baste elastic to waist casing allowance by stitching vertically across it at quarter marks. Fold casing allowance with elastic to wrong side and stitch it in place along bottom edge of elastic with two parallel rows of stitching, stretching elastic as you sew.

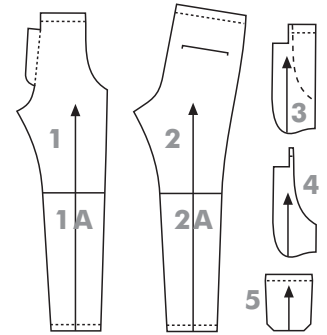

**PATTERN PIECES** cut

1+1A pants front	2
2+2A pants back	2
3 pocket piece	2
4 pocket facing	2
5 back pocket	2

**PATTERN SHEET E** blue

## 29. Peter Pan shirt

134-140-146-152-158-164-170 cm

Pages 62, 65



**MATERIALS**

- 110-110-115-120-125-130-135 cm cotton poplin with slight stretch (CO/EL), stretch/recovery 5%
- 45...64 cm interfacing, Vlieseline® H 180
- 12...14 open-ring snap fasteners, ø 10 mm

**CUTTING**

Trace pattern piece for right front panel from pattern for left front panel, observing markings on small-scale pattern. Cut garment pieces from fabric as indicated on list of pattern pieces, placing center-back edges of pattern pieces on fabric fold and adding 10 mm seam allowances to other edges. Cut also two 3 cm x 18 cm strips for cuff placket bindings.

**SEWING**

Follow instructions for design 18.

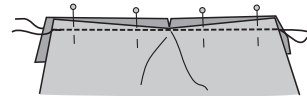

**PATTERN PIECES** cut

1 shoulder yoke	1
2 left front panel	1
2 right front panel	1
3 front facing	1+1
4 back	1
5 sleeve	2
6 sleeve cuff	2
7 pocket	1
8 pocket flap	2
9 collar	2
10 collar stand	2

**PATTERN SHEET E** black

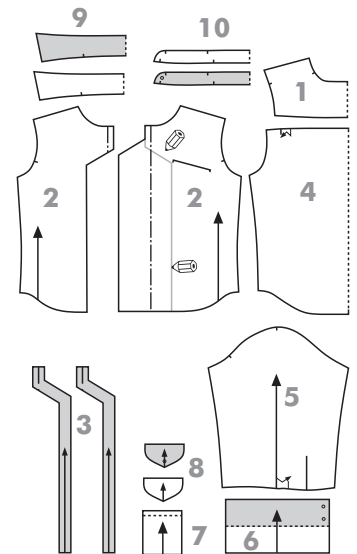

## 30. Never Never Land pants

134-140-146-152-158-164-170 cm Pages 62, 65

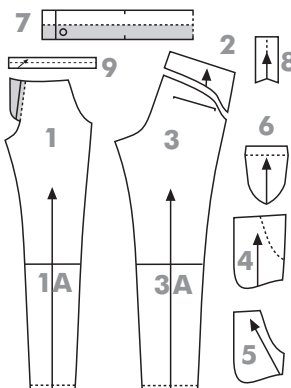
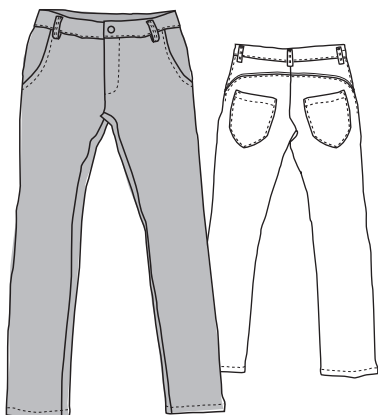

**PATTERN PIECES** cut

1+1A pants front	2
2 back yoke	2
3+3A pants back	2
4 pocket piece	2
5 pocket facing	2
6 back pocket	2
7 waistband	1
8 fly shield	1
9 piping trim*	2

**PATTERN SHEET E** red

**MATERIALS**

- 95-100-105-105-110-115-120 cm stretch satin (CO/PES/EL), stretch/recovery 8%
- 5 cm interfacing, Vlieseline® H 180
- zipper, length 9-9-10-10-11-11-12cm
- snap fastener, ø 15 mm
- matching topstitching thread, Epic no. 80

## CUTTING

Join pattern pieces **1+1A** and **3+3A** before cutting. Cut garment pieces from satin as indicated on list of pattern pieces, placing center-back edge of pattern piece for waistband on fabric fold and adding 10 mm seam allowances to other edges. \*Pattern piece for piping trim includes seam allowances. Cut also 3 cm x 40 cm strip for belt loops.

## SEWING

**Construction techniques:** Stitch seams with straight stitch and finish them with serger or zigzag stitch. Topstitch edges of

pocket openings on pants fronts using presser-foot edge as guide and topstitch seams and other edges close to seamline or edge; use matching topstitching thread.

**Stabilizing:** Fuse interfacing to waistband and fly facing (see areas shaded in grey on small-scale patterns).

**Front-hip pockets:** Pin and stitch pocket facings to edges of pocket openings on pants fronts, right sides together. Clip seam allowances along curves. Understitch seam allowances to pocket facings close to seamline. Fold pocket facings to wrong side of pants fronts and topstitch edges of pocket openings. Pin pocket pieces to

pocket facings right sides together and stitch bottom of each pocket. Pin and machine-baste pockets to waist and side seam allowances of pants fronts.

**Back pockets:** Fold, press and stitch hems at opening edges of back pockets as marked on pattern. Turn and press seam allowances at other pocket edges to wrong side, pin pockets to pants backs as marked on pattern and topstitch in place.

**Joining:** Follow instructions for design 16.

**Belt loops:** Follow instructions for design 16.

**Waistline:** Pin and stitch right side of inner half of waistband to wrong side of pants waist. Fold waistband right sides together and stitch its ends. Trim corners and turn ends of waistband right side out. Turn waistband right way up, turn seam allowance at its free outer edge under and stitch edge to right side of pants waist. Stitch free ends of belt loops to top edge of waistband. Attach snap fastener to waistband as marked on pattern.

## 31. Penguin nightdress

86-92-98-104-110-116-122 cm

Page 54

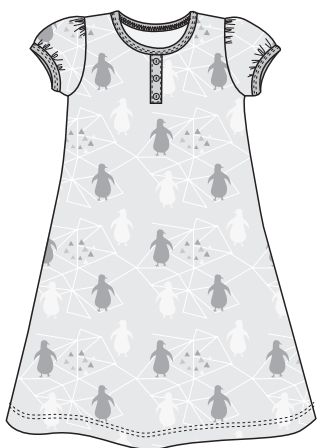

### CUTTING

Cut button band from solid-color and other garment pieces from printed single jersey as indicated on list of pattern pieces, placing center-front and center-back edges of pattern pieces on fabric fold and adding 7 mm seam allowances to all other edges except neckline and bottom edges of sleeves. Cut 3.5 cm wide binding strips from ribbing for finishing neckline and bottom edges of sleeves. If you use a binder attachment on your coverstitch machine to attach the bindings, cut the binding strips in the width that fits the binder.

### SEWING

**Construction techniques:** Stitch seams with serger or with overedge stretch stitch on regular sewing machine. See general instructions for finishing edges with binding on p. 44.

**Sleeves:** Cut two 6 cm pieces of clear elastic tape for gathering sleeve caps. Machine-baste tapes between pattern markings along sleeve caps, placing them on right side of sleeves and stretching them slightly as you sew to gather sleeve caps. On finished garment, clear elastic tapes will be concealed between seam allowances.

Cut two pieces of clear elastic tape for

bottom edges of sleeves (length = child's arm circumference plus 2...3 cm). Machine-baste tapes to bottom edges of sleeves, stretching them evenly as you sew. Finish bottom edges of sleeves with binding, concealing clear elastic tapes within binding.

**Button band:** Fold and press seam allowances at long edges and bottom edge of button band to wrong side. Pin and stitch button band to front panel with straight stitch close to edge.

**Stabilizing shoulder seams:** Cut two pieces of clear elastic tape for stabilizing shoulder seams (measure required length on pattern and add seam allowances). Machine-baste tapes to right side of shoulder seam allowances on back panel (on finished garment, tapes will be concealed between seam allowances).

**Joining:** Pin front and back right sides together and stitch left shoulder seam. Finish neckline with binding. Stitch right shoulder seam. Fold shoulder seam allowances to one side and stitch them flat across neckline binding. Stitch sleeves to armholes. Stitch sleeve underarm seams and side seams. Fold underarm seam allowances to one side and stitch them flat across sleeve-edge bindings. Fold up and press bottom hem and stitch it with 3-thread coverstitch or with twin needle on regular sewing machine. Sew buttons on button band.

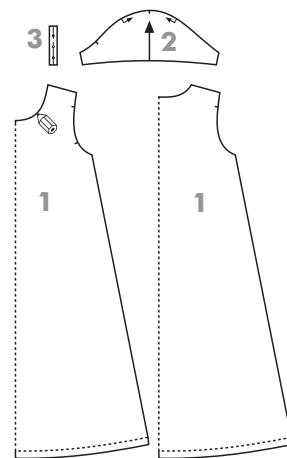

### PATTERN PIECES

PATTERN PIECES	cut
1 front	1
1 back	1
2 sleeve	2
3 button band	1

### PATTERN SHEET E orange

### MATERIALS

- 75-80-85-90-95-100-105 cm printed and a piece of solid-color organic-cotton single jersey (CO/EL), stretch/recovery 30%
- 7 cm ribbing (CO/EL), width 90 cm
- 75...85 cm clear elastic tape, width 5 mm, Framilon®
- 3 small buttons, ø 8 mm

## 32. Big Sis nightdress

128-134-140-146-152-158 cm

Page 54



You can sew the nightdress for girls of height 164-170 cm using the pattern for design 38, women's nightdress.

### MATERIALS

- 110-115-115-120-165-180 cm printed and a piece of solid-color organic-cotton single jersey (CO/EL), stretch/recovery 30%
- 7 cm ribbing (CO/EL), width 90 cm
- 90...100 cm clear elastic tape, width 5 mm, Framilon®
- 3 small buttons, ø 8 mm

### PATTERN PIECES

PATTERN PIECES	cut
1+1A front	1
1+1A back	1
2 sleeve	2
3 button band	1

### PATTERN SHEET E lilac

### CUTTING

Join pattern pieces **1+1A** before cutting. Cut button band from solid-color and other garment pieces from printed single jersey as indicated on list of pattern pieces, placing center-front and center-back edges of pattern pieces on fabric fold and adding 7 mm seam allowances to all other edges except neckline and bottom edges of sleeves. Cut 3.5 cm wide

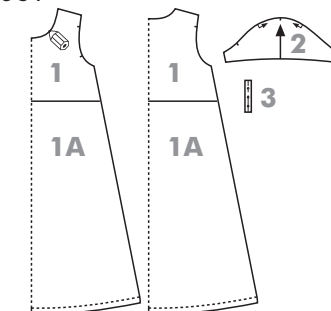

binding strips from ribbing for finishing neckline and bottom edges of sleeves. If you use a binder attachment on your coverstitch machine to attach the bindings, cut the binding strips in the width that fits the binder.

### SEWING

Follow instructions for design 31.



PATTERN PIECES	cut
1 ⇨ front	1
1 back	1
2 sleeve	2
3 sleeve cuff	2
4 button band*	2

**PATTERN SHEET F** green

### MATERIALS

- 45-50-50-55-55-60-60-65 cm printed and a piece of solid-color organic-cotton single jersey (CO/EL), stretch/recovery 30%
- 15 cm ribbing (CO/EL), width 90 cm
- piece of interfacing, Vlieseline® H 180
- 20...25 cm clear elastic tape, width 5 mm, Framilon®
- three snap fasteners, ø 12 mm

### CUTTING

Cut sleeve cuffs from ribbing, button bands from solid-color single jersey and other garment pieces from printed single jersey as indicated on list of pattern pieces, placing center-front and center-back edges of pattern pieces on fabric fold and adding 7 mm seam allowances to all other edges except neckline. \*Pattern piece for button band includes seam allowances.

Cut 3.5 cm wide binding strip from ribbing for finishing neckline. If you use a binder attachment on your coverstitch machine to attach the binding, cut the strip in the width that fits the binder.

### SEWING

**Construction techniques:** Stitch seams with serger or with overedge stretch stitch on regular sewing machine. Stitch coverstitching with 5-thread coverstitch or use suitable decorative stitch on regular

sewing machine (e.g. honeycomb stitch). Stitch front placket with straight stitch. See general instructions for finishing edges with binding on p. 44.

**Stabilizing:** Fuse interfacing to button bands (see area shaded in grey on small-scale pattern).

**Sleeve cuffs:** Stitch sleeve cuffs to bottom edges of sleeves following instructions for design 15.

**Front placket:** Mark center-front line, starting from neckline, on wrong side of front panel with tailor's chalk or by basting. Pin right sides of button bands to wrong side of front panel, placing bands on each side of center-front line and aligning their non-interfaced edges with center-front line. Stitch button bands in place along their non-interfaced edges, placing stitching 1 cm away from center-front line on front panel and ending it 1 cm above bottom edge of button band. Slash placket opening from right side of front panel:

cut from neckline along center-front line as far as 2 cm above ends of stitching lines on button bands and clip diagonally to ends of stitching lines, forming a triangle at bottom of placket.

Fold each button band in half wrong sides together and press. Topstitch folded outer edges of bands close to edge. Fold button bands right way up. Turn seam allowances at interfaced edges of button bands to wrong side, pin edges to right side of placket edges and stitch them in place close to edge. Overlap button bands, pin them together and machine-baste their bottom edges together. Pin and stitch triangle at bottom of placket to button bands right sides together. Finish seam allowances at bottom of placket together.

**Stabilizing shoulder seams:** Stabilize shoulder seams with clear elastic tape following instructions for design 31.

**Joining:** Pin front and back right sides

together and stitch shoulder seams. Finish neckline with binding and leave a little extra at each end of binding. Wrap ends of binding tightly to wrong side and stitch them to neckline binding 5 mm from edges of button bands. Trim excess binding off close to stitching.

Stitch sleeves to armholes. Stitch sleeve underarm seams and side seams. Fold underarm seam allowances to one side at bottom edges of sleeves and stitch them flat for a couple of centimeters. Fold up and press bottom hem as marked on pattern and stitch it with 3-thread coverstitch or with twin needle on regular sewing machine.

**Finishing:** Attach snap fasteners to button bands as marked on pattern.



### MATERIALS

- 90-95-100-105-110-115-120 cm printed and a piece of solid-color organic-cotton single jersey (CO/EL), stretch/recovery 30%
- 15 cm ribbing (CO/EL), width 90 cm
- piece of interfacing, Vlieseline® H 180
- 25...30 cm clear elastic tape, width 5 mm, Framilon®
- 3 snap fasteners, ø 12 mm

PATTERN PIECES	cut
1 ⇨ front	1
1 back	1
2 sleeve	2
3 sleeve cuff	2
4 button band*	2

**PATTERN SHEET F** black

### CUTTING and SEWING

Follow instructions for design 33.

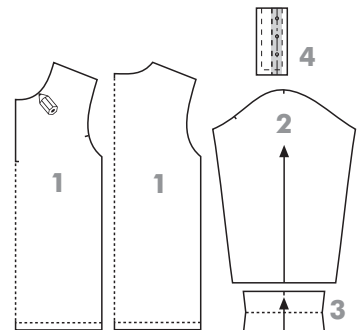



## 35. Fall Asleep pajama pants

86-92-98-104-110-116-122-128 cm

Page 54

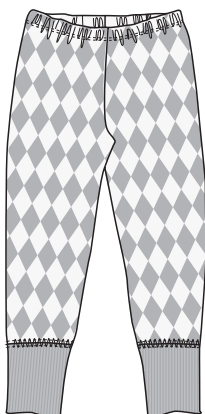

### MATERIALS

- 50-50-55-60-60-65-70-75 cm printed organic-cotton single jersey (CO/EL), stretch/recovery 30%
- 25 cm ribbing (CO/EL)
- 50...60 cm elastic, width 20 mm

### CUTTING

Cut pants panels from single jersey and bottom-leg cuffs from ribbing as indicated on list of pattern pieces, adding 7 mm seam allowances to all edges.

### SEWING

**Construction techniques:** Stitch seams with serger or with overedge stretch stitch on regular sewing machine. Stitch coverstitching with 5-thread coverstitch or use suitable decorative stitch on regular sewing machine (e.g. honeycomb stitch).

**Bottom edges of legs:** Stitch bottom-leg cuffs to bottom edges of legs as follows: Pin and stitch one edge of cuff to bottom edge of leg right sides together, stretching cuff slightly as you sew. Press seam open, fold cuff in half wrong sides

together and pin its free edge to bottom-leg seam. Stitch cuff in place from right side of leg with 5-thread coverstitch, placing stitching in the middle of seamline.

**Joining:** Fold pants panels in half right sides together and stitch leg inseams. Fold seam allowances to one side and stitch them flat for a couple of centimeters at bottom edges of legs. Turn left pants half right side out and place it within right pants half right sides together. Stitch crotch seam, leaving small opening across waist casing allowance at back for inserting elastic.

**Waistline:** Fold, press and stitch waist casing as marked on pattern. Measure and cut piece of elastic to fit the child and insert it into waist casing. Stitch ends of elastic together and close opening on casing by hand-stitching.

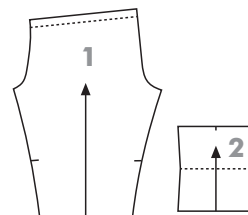

### PATTERN PIECES

PATTERN PIECES	cut
1 pants panel	2
2 bottom-leg cuff	2

### PATTERN SHEET F orange

## 36. Jim's pajama pants

134-140-146-152-158-164-170 cm

Page 54

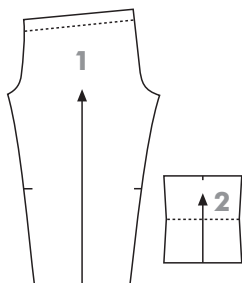
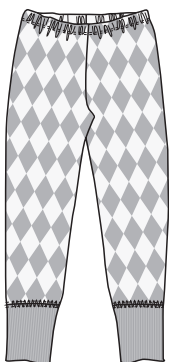

### PATTERN PIECES

PATTERN PIECES	cut
1 pants panel	2
2 bottom-leg cuff	2

### PATTERN SHEET F lilac

### CUTTING and SEWING

Follow instructions for design 35.

### MATERIALS

- 75-80-85-85-90-95-95 cm printed organic-cotton single jersey (CO/EL), stretch/recovery 30%
- 30 cm ribbing (CO/EL)
- 62...70 cm elastic, width 30 mm

## 37. Sandman night jumpsuit

104-110-116-122-128-134-140-146 cm

Page 55

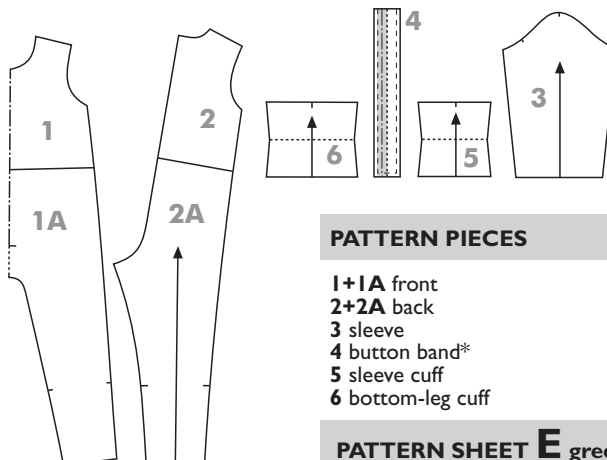
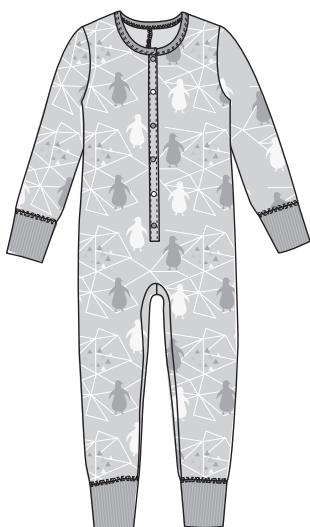

### PATTERN PIECES

PATTERN PIECES	cut
1+1A front	1
2+2A back	2
3 sleeve	2
4 button band*	2
5 sleeve cuff	2
6 bottom-leg cuff	2

### PATTERN SHEET E green

### MATERIALS

- 95-100-105-110-120-130-140-155 cm printed and a piece of solid-color organic-cotton single jersey (CO/EL), stretch/recovery 30%
- 25 cm striped ribbing (CO/EL), width 140 cm
- piece of interfacing, Vlieseline® H 180
- 25...30 cm clear elastic tape, width 5 mm, Framilon®
- 6...7 plastic snap fasteners, ø 12 mm, Prym Colors

## CUTTING

Join pattern pieces **1+1A** and **2+2A** before cutting. Cut sleeve cuffs and bottom-leg cuffs from ribbing, button bands from solid-color single jersey and other garment pieces from printed single jersey as indicated on list of pattern pieces, placing center-front of pattern on fabric fold and adding 7 mm seam allowances to all other edges except neckline. \*Pattern piece for button band includes seam allowances.

Cut 4.5 cm wide binding strip from ribbing for finishing neckline. If you use a binder attachment on your coverstitch machine to attach the binding, cut the strip in the width that fits the binder.

## SEWING

**Construction techniques:** Stitch seams with serger or with overedge stretch stitch on regular sewing machine. Stitch coverstitching with 5-thread coverstitch or use suitable decorative stitch on regular sewing machine (e.g. honeycomb stitch). Stitch front placket with straight stitch. See general instructions for finishing edges with binding on p. 44.

**Stabilizing:** Fuse interfacing to button bands (see area shaded in grey on small-scale pattern). Stabilize shoulder seams with clear elastic tape following instructions for design 31.

**Sleeve cuffs:** Stitch sleeve cuffs to bottom edges of sleeves following instructions for design 15.

**Front placket:** Construct front placket following instructions for design 33.

**Joining:** Pin front and back panels right sides together and stitch shoulder seams. Stitch center-back seam. Finish neckline with binding and leave a little extra at each end of binding. Wrap ends of binding tightly to wrong side and stitch them to neckline binding 5 mm from edges of button bands. Trim excess binding off close to stitching.

Stitch sleeves to armholes. Stitch sleeve

underarm seams and side seams as continuous seams from bottom edges of sleeves to bottom edges of legs. Fold underarm seam allowances to one side at sleeve edges and stitch them flat for a few of centimeters. Stitch bottom-leg cuffs to bottom edges of legs in the same way as sleeve cuffs to sleeves. Stitch leg inseams. Fold inseam seam allowances to one side at bottom edges of legs and stitch them flat for a couple of centimeters.

**Finishing:** Attach snap fasteners to button bands as shown in design sketch.

# 38. Sweet Mama nightdress 34/36 - 38/40 - 42/44 - 46/48 - 50/52 (women's sizes) Page 57

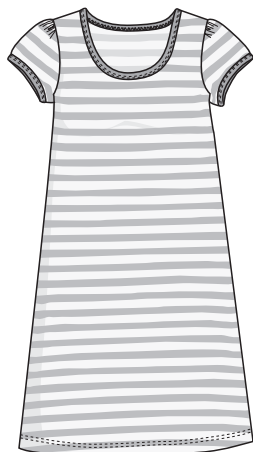

You'll find women's size charts on our blog!

## CUTTING

Join pattern pieces **1+1A** and **2+1A** before cutting. Cut garment pieces from single jersey as indicated on list of pattern pieces, placing center-front and center-back edges of pattern pieces on fabric fold and adding 7 mm seam allowances to all other edges except neckline and bottom edges of sleeves.

Cut 3.5 cm wide binding strips from ribbing for finishing neckline and bottom edges of sleeves. If you use a binder attachment on your coverstitch machine to attach the bindings, cut the binding strips in the width that fits the binder.

## SEWING

**Construction techniques:** Stitch seams with serger or with overedge stretch stitch on regular sewing machine. See general instructions for finishing edges with binding on p. 44.

**Sleeves:** Cut two 6 cm pieces of clear elastic tape for gathering sleeve caps. Machine-baste tapes between pattern markings along sleeve caps, placing them on right side of sleeves and stretching them slightly as you sew to gather sleeve caps. On finished garment, clear elastic tapes will be concealed between seam allowances. Finish bottom edges of sleeves with binding.

**Stabilizing shoulder seams:** Stabilize shoulder seams with clear elastic tape following instructions for design 31.

**Joining:** Pin front and back right sides together and stitch left shoulder seam. Finish neckline with binding. Stitch right shoulder seam. Fold shoulder seam allowances to one side and stitch them flat across neckline binding. Stitch sleeves to armholes. Stitch sleeve underarm seams and side seams. Fold underarm seam allowances to one side and stitch them flat across sleeve-edge bindings. Fold up and press bottom hem and stitch it with 3-thread coverstitch or with twin needle on regular sewing machine.

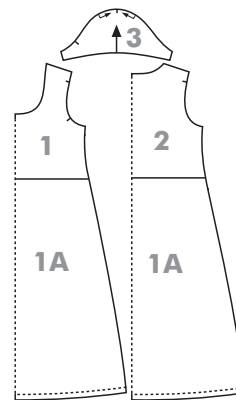

## PATTERN PIECES cut

<b>1+1A</b> front	1
<b>2+1A</b> back	1
<b>3</b> sleeve	2

## PATTERN SHEET F red

## MATERIALS

- 140-140-185-250-255 cm striped organic-cotton single jersey (CO/EL), stretch/recovery 30%, width 160 cm
- 7 cm ribbing
- 40...50 cm clear elastic tape, width 5 mm, Framilon®

# 39. Cameraman pajama top 48-50-52-54 (men's sizes) Page 57



You'll find men's size charts on our blog!

## CUTTING

Cut garment pieces from single jersey as indicated on list of pattern pieces, placing center-front and center-back edges of pattern pieces on fabric fold and adding 7 mm seam allowances to all other edges except neckline and bottom edges of sleeves.

Cut 4.5 cm wide binding strips from ribbing for finishing neckline and bottom edges of sleeves. If you use a binder attachment on your coverstitch machine to attach the bindings, cut the binding strips in the width that fits the binder.

## SEWING

**Construction techniques:** Stitch seams with serger or with overedge stretch stitch on regular sewing machine. See

general instructions for finishing edges with binding on p. 44.

**Stabilizing shoulder seams:** Stabilize shoulder seams with clear elastic tape following instructions for design 31.

**Joining:** Finish bottom edges of sleeves with binding. Pin front and back right sides together and stitch left shoulder seam. Finish neckline with binding. Stitch right shoulder seam. Fold shoulder seam allowances to one side and stitch them flat across neckline binding. Stitch sleeves to armholes. Stitch sleeve underarm seams and side seams. Fold underarm seam allowances to one side and stitch them flat across sleeve-edge bindings. Fold up and press bottom hem and stitch it with 3-thread coverstitch or with twin needle on regular sewing machine.



## PATTERN PIECES cut

<b>1</b> front	1
<b>1</b> back	1
<b>2</b> sleeve	2

## PATTERN SHEET A grey

## MATERIALS

- 110-110-110-115 cm printed organic-cotton single jersey (CO/EL), stretch/recovery 30%, width 160 cm
- 9 cm ribbing
- 30...40 cm clear elastic tape, width 5 mm, Framilon®

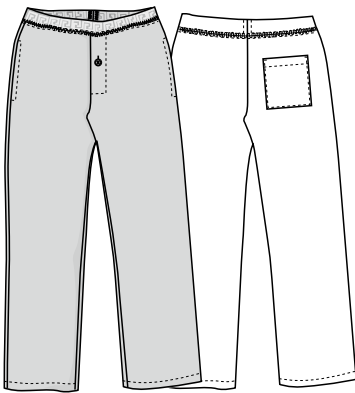
**MATERIALS**

- 155-160-165-170 cm cotton chambray or poplin (CO)
- 80...90 cm patterned elastic, width 40 mm
- piece of interfacing for stabilizing buttonhole and button areas
- button, ø 15 mm

**CUTTING**

Join pattern pieces **1+1A** and **2+2A** before cutting. Cut garment pieces from fabric as indicated on list of pattern pieces, adding 10 mm seam allowances to all edges. Take note of pattern markings for fly extensions on left and right pants fronts.

**SEWING**

**Construction techniques:** Stitch seams with straight stitch and finish them with serger or zigzag stitch.

**Stabilizing:** Fuse small pieces of interfacing to wrong side of buttonhole and button areas on pants fronts (see area shaded in grey on small-scale pattern).

**Back pocket:** Stitch hem at opening edge of back pocket as marked on pattern. Turn and press seam allowances at other pocket edges to wrong side. Pin and stitch pocket to right pants back as marked on pattern.

**Front fly:** Fold fly extensions on pants fronts to wrong side along marked fold-lines and press. Turn seam allowance at vertical edge of fly extension on left pants front (= fly facing) under, pin edge to pants front and stitch it in place close to edge. Stitch buttonhole on left edge of fly as marked on pattern. Stitch narrow hem along vertical edge of fly extension on right pants front. Fold fly extension wrong sides together along pressed fold to form fly underlap and machine-baste along its top and bottom edges.

**Joining:** Pin and stitch pocket pieces to side-seam edges of pants fronts and backs right sides together, matching pattern markings for pocket openings. Serge or zigzag side seam allowances, starting from waist edge and ending a few centimeters below bottom ends of pocket openings. Understitch seam allowances along pocket openings to pocket pieces close to seam-line.

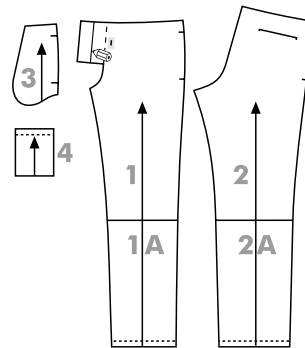

Pin pants fronts and backs right sides together and stitch side seams from waist edge to upper pattern marking for pocket opening and from lower pattern marking for pocket opening to bottom edge of leg. Fold pocket piece on each pants front to wrong side and topstitch edge of pocket opening using presser-foot edge as guide. Pin pocket pieces right sides together and stitch them together. Finish pocket seam allowances together and, at the same time, finish side seam allowances together from bottom end of pocket openings to bottom edges of legs. Stitch short horizontal rows of reinforcing back-and-forth stitching at both ends of pocket openings from right side.

Stitch leg inseams. Place pants legs within one another right sides together and stitch crotch seam from back waist to bottom of front fly. Finish entire crotch seam as well as bottom edge of fly underlap on right pants front. Place fly underlap under left fly edge, pin fly in position and

stitch horizontal row of stitching across bottom of fly. Machine-baste top edges of fly and pockets to waist seam allowance on pants front.

**Waistline:** Cut piece of elastic to fit the wearer's waist and stitch its ends together to form circle. Mark elastic into quarters. Pin elastic to pants waist edge wrong sides together and stitch it in place with 10 mm seam allowance, stretching it as you sew and aligning quarter marks with pants center-front, center-back and side seams. Trim waist seam allowance slightly, fold elastic right way up and stitch its bottom edge to right side of waist, concealing waist seam allowance under it; use either straight stitch, zigzag stitch or 5-thread coverstitch for stitching.

**Finishing:** Sew button on front fly. Fold up and stitch hems at bottom edges of legs as marked on pattern.

**PATTERN PIECES**

PATTERN PIECES	cut
<b>1+1A</b> pants front	1+1
<b>2+2A</b> pants back	2
<b>3</b> side pocket	2+2
<b>4</b> back pocket	1

**PATTERN SHEET F** blue

You'll find men's size charts on our blog!

**EDGE FINISH WITH KNIT BINDING**

The binding can be cut either from ribbing or from the same knit as the rest of the garment. The most suitable knits are those that do not curl, such as interlock knit or rib knit.

The binding can be stitched to the garment using a binder attachment on a **serger**. When using a binder, the binding is cut in the width specified by the serger instructions. The exact cut length of the binding cannot be specified in advance and you'll find the best technique for applying the binding by experimenting. The edge finish will be neat and look very professional.

If you want to attach the binding on a **regular sewing machine**, use the following method.

**1.** Measure the length of the edge to be finished (=X cm) on the pattern piece.

**2.** Determine the length of the binding.  
**Binding cut from the knit used for the actual garment** (stretch/recovery 20-30%):

- length of binding = 0.85 x length of the edge to be finished, X cm

**Binding cut from ribbing** (stretch/recovery 40-50%):

- length of binding = 0.70 x length of the edge to be finished, X cm

**Note!** As the elasticity of different knits tends to vary, the length of the binding should be checked by experimenting on a piece of scrap fabric before applying the binding to the garment.

Cut the binding in the width of 3.5 cm if the finished width of the binding is supposed to be 10-12 mm.

**3.** Applying the binding:  
Mark both binding and edge to be finished into quarters.

Stitch one edge of binding to garment's edge, right sides together, aligning quarter marks and stretching binding along curved portions of garment's edge. Use straight stitch on a regular sewing machine, or alternatively stitch on a serger. *Stitching I.*

Fold the other edge of binding over to wrong side of garment's edge and topstitch binding with twin needle (or with 3-thread coverstitch) from right side close to edge. *Stitching II.*

Neaten edge of binding on wrong side of garment by carefully trimming off excess seam allowance.

**Note!** When finishing the neckline of a T-shirt with knit binding, stretch both the neck edge and the binding as you sew in order to produce an elastic seam.

Pictured here is a binder for an industrial coverstitch machine. Corresponding binder accessories are also available for most home coverstitch machines.

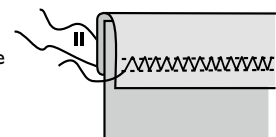
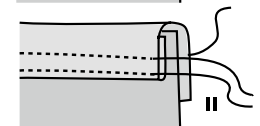
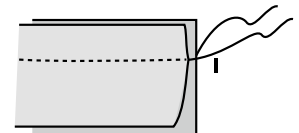

## FRONT PLACKET

Design 26

**1.** Finish raw side and bottom edges of placket piece. Slash placket opening on placket piece as marked on pattern. Pin placket piece to front panel right sides together (place slashed placket opening to the right of center-front line on front panel). Stitch along edges of placket with 3 mm seam allowance, gradually decreasing seam allowance as you approach bottom of placket. Slash placket opening on front panel between stitching lines.

**2. and 3.** Understitch seam allowances at each edge of placket opening to placket piece close to seamline.

**4.** Turn placket piece to wrong side of front panel. Fold placket piece on right-hand side of placket wrong sides together along marked foldline to form placket underlap.

**5.** Overlap placket piece on left side of placket (= placket facing) with placket underlap, pin them together and machine-baste their bottom edges together from wrong side.

**6.** Pin placket facing and placket underlap to bottom of placket from right side of front panel and secure them in position by stitching a rectangle at bottom of placket through all layers.

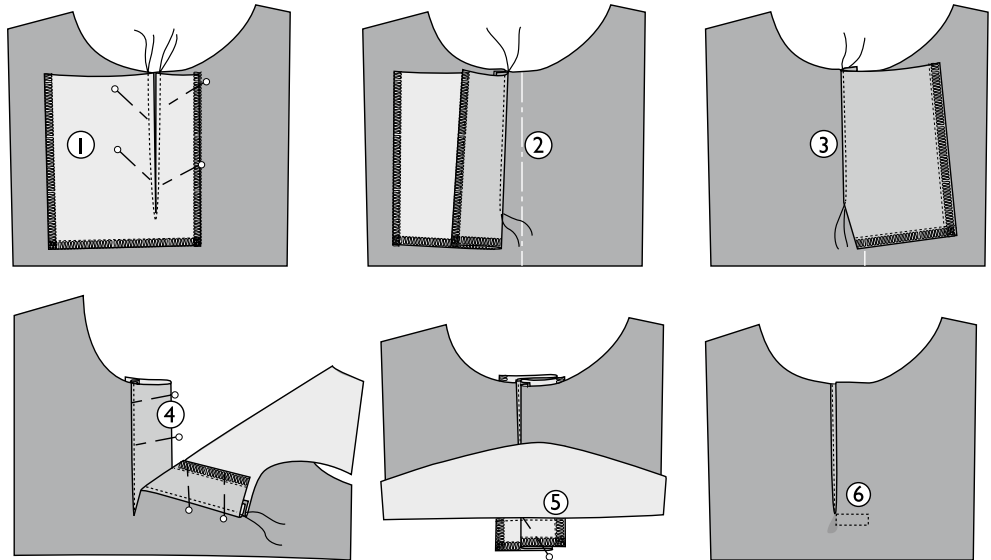

## FLY-FRONT ZIPPER

Designs 16, 30

The zipper application is for boys' pants. For girls' pants, interchange left and right in the instructions.

**1.** Construct fly shield: Fold fly shield piece in half, right sides together, and stitch bottom edges together. Turn shield right side out and serge or zigzag raw long edges together. Stitch zipper tape to fly shield.

**2.** Finish raw edges of zipper placket.

**3.** Fold seam allowance on narrower edge of zipper placket to wrong side. Pin and stitch fly shield under placket edge.

**4.** Pin the other zipper tape to fly facing from wrong side, open zipper and stitch it in place.

**5.** Topstitch fly facing to garment's front. Fold fly shield out of the way as you sew.  
**(6.** Stitch bar-tack using short zigzag stitch at bottom of placket, catching fly shield in stitching.)

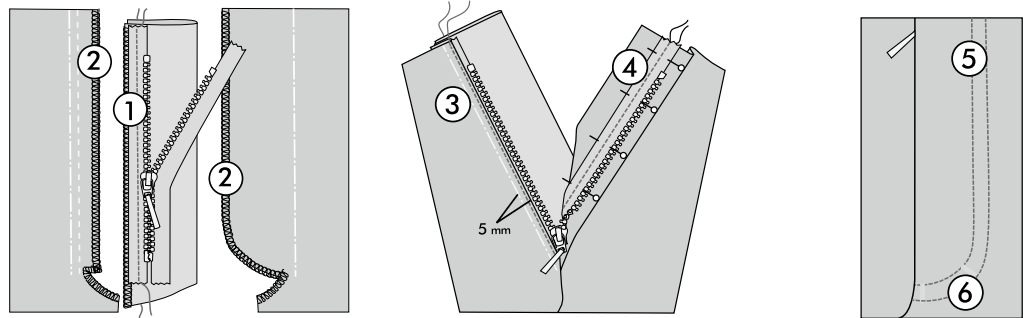

## COLLAR WITH A STAND

Designs 18, 29

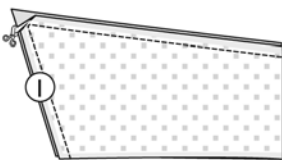

**1.** Pin collar pieces right sides together and stitch their ends and outer edges. Trim seam allowances across corners, press seams open and turn collar right side out. Topstitch around collar close to edge and machine-baste its open bottom edges together at the same time.

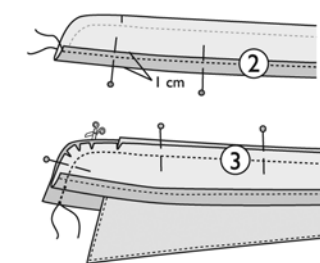

**2.** Turn seam allowance at bottom edge of inner collar stand to wrong side and stitch along edge using presser-foot edge as guide.  
**3.** Pin bottom edge of collar to top edge of inner collar stand, with inner collar stand and upper collar right

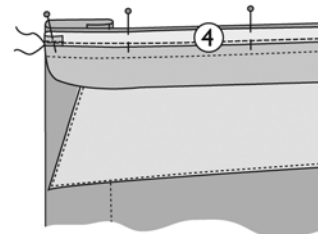

sides together. Pin and stitch inner and outer collar stands right sides together, with collar in between. Trim and clip seam allowances around corners.  
**4.** Turn collar stand right side out. Pin and stitch bottom edge of outer collar stand to garment's neckline right sides together.

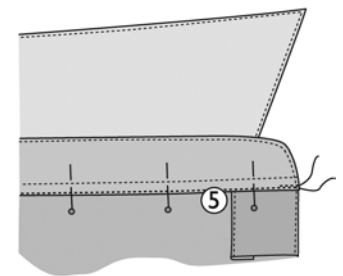

**5.** Pin bottom edge of inner collar stand to neckline carefully and stitch it in place close to edge. Topstitch around collar stand and, at the same time, topstitch garment's front edges close to edge.



**BUNNY**  
Design 15

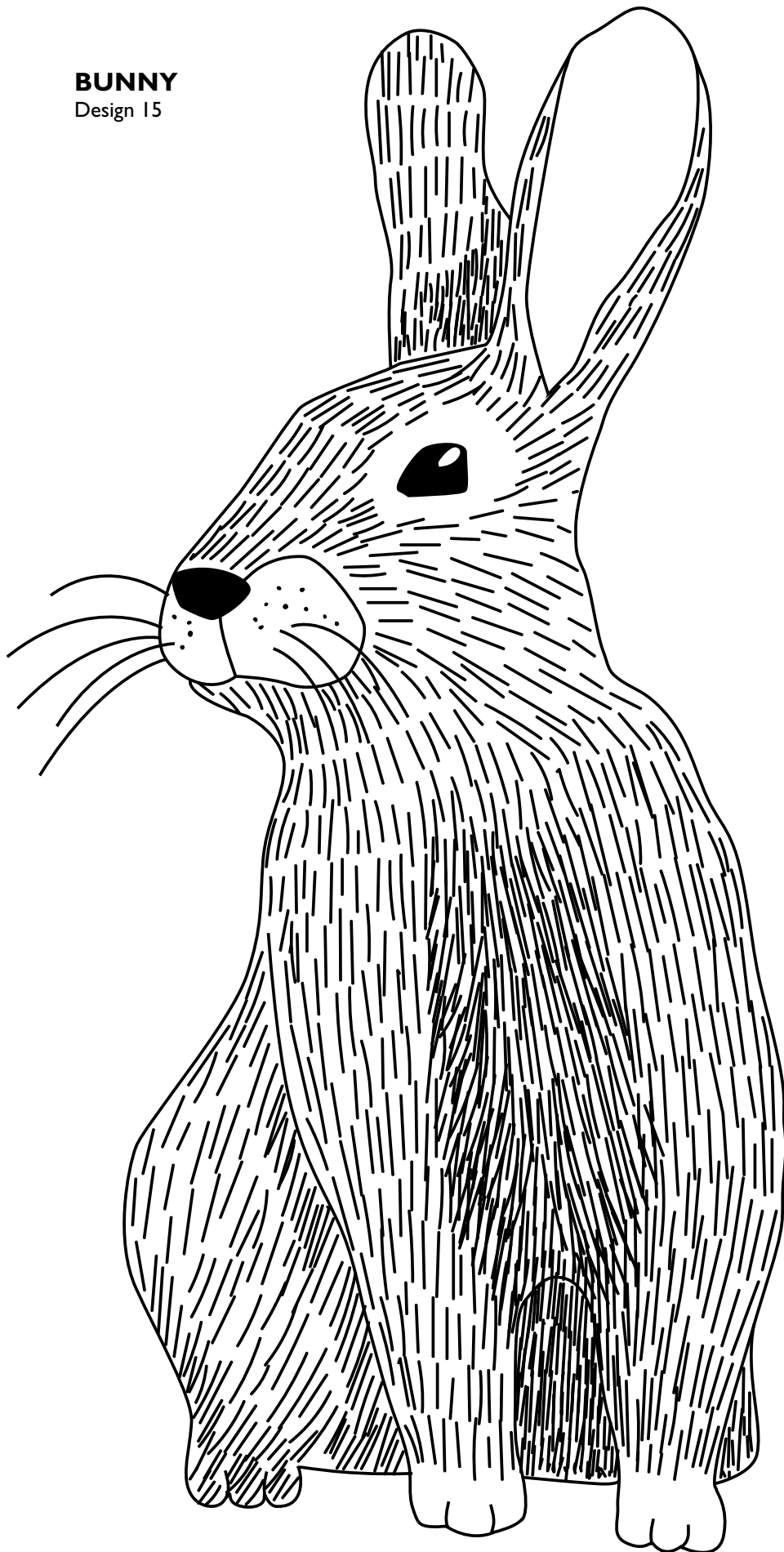

Dear Subscriber to  
**OTTOBRE design®**  
magazine,

We would like to offer you  
a small bonus:

The pattern and instructions  
for the merino wool beanie  
featured on pages 4-17 have  
been sent to you by email.

If you haven't received the  
pattern, please update your  
contact information on our  
website at

[www.ottobredesign.com/  
beanie](http://www.ottobredesign.com/beanie)



Non-subscribers can buy  
the pattern for the beanie  
in our online shop at

[www.ottobredesign.  
com/subscription/  
other.php](http://www.ottobredesign.com/subscription/other.php)

The price of the pattern  
is EUR 3.50, and it can  
be paid by credit card or  
PayPal. The pattern is an  
e-pattern, and you will  
receive an email with a link  
for downloading it.